



ISP1562

Hi-Speed Universal Serial Bus PCI Host Controller

Rev. 01 — 14 July 2005

Product data sheet



1. General description

The ISP1562 is a Peripheral Component Interconnect (PCI)-based, single-chip Universal Serial Bus (USB) Host Controller. It integrates two Original USB Open Host Controller Interface (OHCI) cores, one Hi-Speed USB Enhanced Host Controller Interface (EHCI) core, and two transceivers that are compliant with Hi-Speed USB and Original USB. The functional parts of the ISP1562 are fully compliant with *Universal Serial Bus Specification Rev. 2.0*, *Open Host Controller Interface Specification for USB Rev. 1.0a*, *Enhanced Host Controller Interface Specification for Universal Serial Bus Rev. 1.0*, *PCI Local Bus Specification Rev. 2.2*, and *PCI Bus Power Management Interface Specification Rev. 1.1*.

The integrated high performance USB transceivers allow the ISP1562 to handle all Hi-Speed USB transfer speed modes: high-speed (480 Mbit/s), full-speed (12 Mbit/s) and low-speed (1.5 Mbit/s). The ISP1562 provides two downstream ports, allowing simultaneous connection of USB devices at different speeds.

The ISP1562 is fully compatible with various operating system drivers, such as Microsoft Windows standard OHCI and EHCI drivers that are present in Windows XP, Windows 2000 and Red Hat Linux.

The ISP1562 directly interfaces to any 32-bit, 33 MHz PCI bus. Its PCI pins can source 3.3 V. The PCI interface fully complies with *PCI Local Bus Specification Rev. 2.2*.

The ISP1562 is ideally suited for use in Hi-Speed USB mobile applications and embedded solutions. The ISP1562 uses a 12 MHz crystal.

2. Features

- Complies with *Universal Serial Bus Specification Rev. 2.0*
- Supports data transfer at high-speed (480 Mbit/s), full-speed (12 Mbit/s) and low-speed (1.5 Mbit/s)
- Two Original USB OHCI cores comply with *Open Host Controller Interface Specification for USB Rev. 1.0a*
- One Hi-Speed USB EHCI core complies with *Enhanced Host Controller Interface Specification for Universal Serial Bus Rev. 1.0*
- Supports PCI 32-bit, 33 MHz interface compliant with *PCI Local Bus Specification Rev. 2.2*, with support for D3_{cold} standby and wake-up modes; all I/O pins are 3.3 V standard
- Compliant with *PCI Bus Power Management Interface Specification Rev. 1.1* for all hosts (EHCI and OHCI), and supports all power states: D0, D1, D2, D3_{hot} and D3_{cold}

PHILIPS

- CLKRUN support for mobile applications, such as internal notebook design
- Configurable subsystem ID and subsystem Vendor ID through external EEPROM
- Digital and analog power separation for better Electro-Magnetic Interference (EMI) and Electro-Static Discharge (ESD) protection
- Supports hot Plug and Play and remote wake-up of peripherals
- Supports individual power switching and individual overcurrent protection for downstream ports
- Supports partial dynamic port-routing capability for downstream ports that allows sharing of the same physical downstream ports between the Original USB Host Controller and the Hi-Speed USB Host Controller
- Uses 12 MHz crystal oscillator to reduce system cost and EMI emissions
- Supports dual power supply: PCI $V_{aux(3V3)}$ and V_{CC}
- Operates at +3.3 V power supply input
- Low power consumption
- Full industrial operating temperature range from $-40\text{ }^{\circ}\text{C}$ to $+85\text{ }^{\circ}\text{C}$
- Full-scan design with high fault coverage (93 % to 95 %) ensures high quality
- Available in LQFP100 package.

3. Applications

- Digital consumer appliances
- Notebook
- PCI add-on card
- PC motherboard
- Set-Top Box (STB)
- Web appliances.

4. Ordering information

Table 1: Ordering information

| Type number | Package | | Version |
|-------------|---------|---|----------|
| | Name | Description | |
| ISP1562BE | LQFP100 | plastic low profile quad flat package; 100 leads; body 14 x 14 x 1.4 mm | SOT407-1 |

5. Block diagram

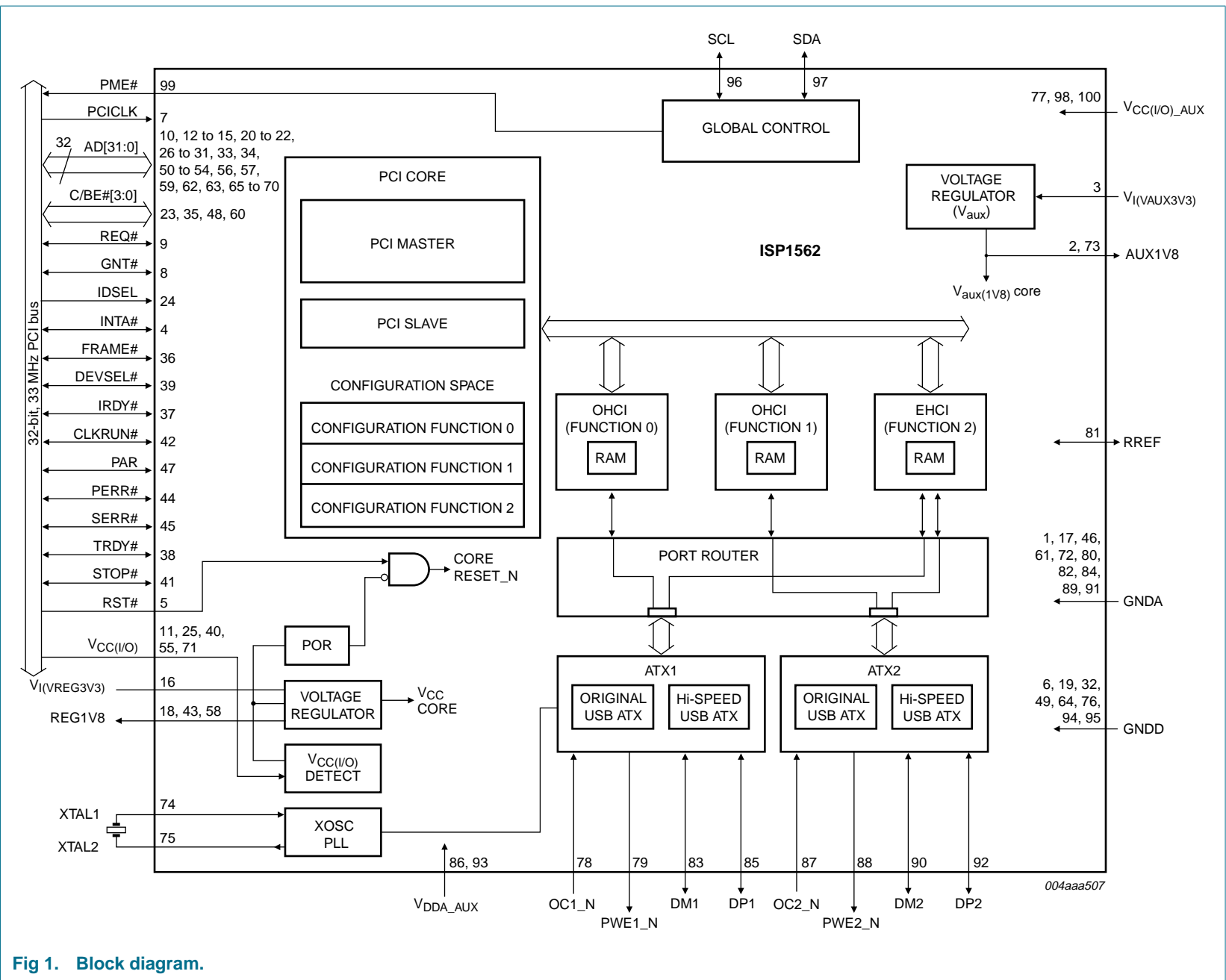

Fig 1. Block diagram.

6. Pinning information

6.1 Pinning

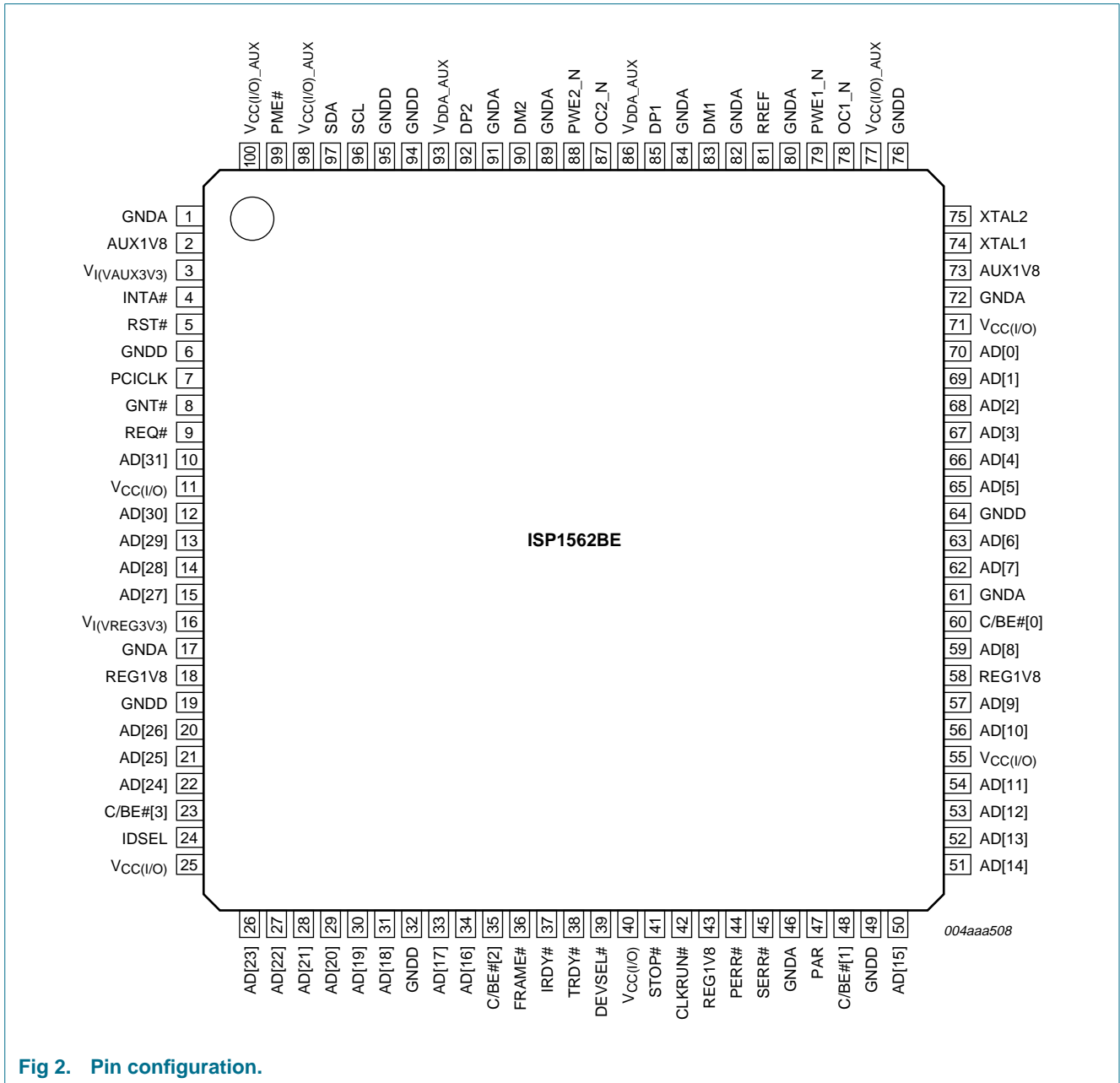

Fig 2. Pin configuration.

6.2 Pin description

Table 2: Pin description

| Symbol ^[1] | Pin | Type | Description |
|-----------------------|-----|------|---|
| GNDA | 1 | - | analog ground |
| AUX1V8 | 2 | - | 1.8 V auxiliary output voltage; only for voltage conditioning; cannot be used to supply power to external components; connected to 100 nF and 20 μ F capacitors |
| $V_{I(VAUX3V3)}$ | 3 | - | 3.3 V auxiliary input voltage; add a 100 nF decoupling capacitor |
| INTA# | 4 | I/O | PCI interrupt PCI pad; 3.3 V signaling; open-drain |
| RST# | 5 | I | PCI reset; used to bring PCI-specific registers, sequencers and signals to a consistent state 3.3 V input pad; push-pull; CMOS |
| GNDD | 6 | - | digital ground |
| PCICLK | 7 | I | PCI system clock (33 MHz) PCI pad; 3.3 V signaling |
| GNT# | 8 | I/O | PCI grant; indicates to the agent that access to the bus is granted PCI pad; 3.3 V signaling |
| REQ# | 9 | I/O | PCI request; indicates to the arbitrator that the agent wants to use the bus PCI pad; 3.3 V signaling |
| AD[31] | 10 | I/O | bit 31 of multiplexed PCI address and data PCI pad; 3.3 V signaling |
| $V_{CC(I/O)}$ | 11 | - | 3.3 V supply voltage; used to power pads; add a 100 nF decoupling capacitor |
| AD[30] | 12 | I/O | bit 30 of multiplexed PCI address and data PCI pad; 3.3 V signaling |
| AD[29] | 13 | I/O | bit 29 of multiplexed PCI address and data PCI pad; 3.3 V signaling |
| AD[28] | 14 | I/O | bit 28 of multiplexed PCI address and data PCI pad; 3.3 V signaling |
| AD[27] | 15 | I/O | bit 27 of multiplexed PCI address and data PCI pad; 3.3 V signaling |
| $V_{I(VREG3V3)}$ | 16 | - | 3.3 V regulator input voltage; add a 100 nF decoupling capacitor |
| GNDA | 17 | - | analog ground |
| REG1V8 | 18 | - | 1.8 V regulator output voltage; only for voltage conditioning; cannot be used to supply power to external components; connected to 100 nF and 20 μ F capacitors |
| GNDD | 19 | - | digital ground |
| AD[26] | 20 | I/O | bit 26 of multiplexed PCI address and data PCI pad; 3.3 V signaling |
| AD[25] | 21 | I/O | bit 25 of multiplexed PCI address and data PCI pad; 3.3 V signaling |
| AD[24] | 22 | I/O | bit 24 of multiplexed PCI address and data PCI pad; 3.3 V signaling |

Table 2: Pin description...continued

| Symbol [1] | Pin | Type | Description |
|----------------------|-----|------|--|
| C/BE#[3] | 23 | I/O | byte 3 of multiplexed PCI bus command and byte enable PCI pad; 3.3 V signaling |
| IDSEL | 24 | I | PCI initialization device select; used as a chip select during configuration read and write transactions PCI pad; 3.3 V signaling |
| V _{CC(I/O)} | 25 | - | 3.3 V supply voltage; used to power pads; add a 100 nF decoupling capacitor |
| AD[23] | 26 | I/O | bit 23 of multiplexed PCI address and data PCI pad; 3.3 V signaling |
| AD[22] | 27 | I/O | bit 22 of multiplexed PCI address and data PCI pad; 3.3 V signaling |
| AD[21] | 28 | I/O | bit 21 of multiplexed PCI address and data PCI pad; 3.3 V signaling |
| AD[20] | 29 | I/O | bit 20 of multiplexed PCI address and data PCI pad; 3.3 V signaling |
| AD[19] | 30 | I/O | bit 19 of multiplexed PCI address and data PCI pad; 3.3 V signaling |
| AD[18] | 31 | I/O | bit 18 of multiplexed PCI address and data PCI pad; 3.3 V signaling |
| GNDD | 32 | - | digital ground |
| AD[17] | 33 | I/O | bit 17 of multiplexed PCI address and data PCI pad; 3.3 V signaling |
| AD[16] | 34 | I/O | bit 16 of multiplexed PCI address and data PCI pad; 3.3 V signaling |
| C/BE#[2] | 35 | I/O | byte 2 of multiplexed PCI bus command and byte enable PCI pad; 3.3 V signaling |
| FRAME# | 36 | I/O | PCI cycle frame; driven by the master to indicate the beginning and duration of an access PCI pad; 3.3 V signaling |
| IRDY# | 37 | I/O | PCI initiator ready; indicates the ability of the initiating agent to complete the current data phase of a transaction PCI pad; 3.3 V signaling |
| TRDY# | 38 | I/O | PCI target ready; indicates the ability of the target agent to complete the current data phase of a transaction PCI pad; 3.3 V signaling |
| DEVSEL# | 39 | I/O | PCI device select; indicates if any device is selected on the bus PCI pad; 3.3 V signaling |
| V _{CC(I/O)} | 40 | - | 3.3 V supply voltage; used to power pads; add a 100 nF decoupling capacitor |
| STOP# | 41 | I/O | PCI stop; indicates that the current target is requesting the master to stop the current transaction PCI pad; 3.3 V signaling |
| CLKRUN# | 42 | I/O | PCI CLKRUN signal; pull-down to ground through a 10 kΩ resistor PCI pad; 3.3 V signaling; open-drain |

Table 2: Pin description...continued

| Symbol [1] | Pin | Type | Description |
|----------------------|-----|------|--|
| REG1V8 | 43 | - | 1.8 V regulator output voltage; only for voltage conditioning; cannot be used to supply power to external components; add a 100 nF decoupling capacitor |
| PERR# | 44 | I/O | PCI parity error; used to report data parity errors during all PCI transactions, except a Special Cycle PCI pad; 3.3 V signaling |
| SERR# | 45 | I/O | PCI system error; used to report address parity errors and data parity errors on the Special Cycle command, or any other system error in which the result will be catastrophic PCI pad; 3.3 V signaling; open-drain |
| GNDA | 46 | - | analog ground |
| PAR | 47 | I/O | PCI parity PCI pad; 3.3 V signaling |
| C/BE#[1] | 48 | I/O | byte 1 of multiplexed PCI bus command and byte enable PCI pad; 3.3 V signaling |
| GNDD | 49 | - | digital ground |
| AD[15] | 50 | I/O | bit 15 of multiplexed PCI address and data PCI pad; 3.3 V signaling |
| AD[14] | 51 | I/O | bit 14 of multiplexed PCI address and data PCI pad; 3.3 V signaling |
| AD[13] | 52 | I/O | bit 13 of multiplexed PCI address and data PCI pad; 3.3 V signaling |
| AD[12] | 53 | I/O | bit 12 of multiplexed PCI address and data PCI pad; 3.3 V signaling |
| AD[11] | 54 | I/O | bit 11 of multiplexed PCI address and data PCI pad; 3.3 V signaling |
| V _{CC(I/O)} | 55 | - | 3.3 V supply voltage; used to power pads; add a 100 nF decoupling capacitor |
| AD[10] | 56 | I/O | bit 10 of multiplexed PCI address and data PCI pad; 3.3 V signaling |
| AD[9] | 57 | I/O | bit 9 of multiplexed PCI address and data PCI pad; 3.3 V signaling |
| REG1V8 | 58 | - | 1.8 V regulator output voltage; only for voltage conditioning; cannot be used to supply power to external components; add a 100 nF decoupling capacitor |
| AD[8] | 59 | I/O | bit 8 of multiplexed PCI address and data PCI pad; 3.3 V signaling |
| C/BE#[0] | 60 | I/O | byte 0 of multiplexed PCI bus command and byte enable PCI pad; 3.3 V signaling |
| GNDA | 61 | - | analog ground |
| AD[7] | 62 | I/O | bit 7 of multiplexed PCI address and data PCI pad; 3.3 V signaling |
| AD[6] | 63 | I/O | bit 6 of multiplexed PCI address and data PCI pad; 3.3 V signaling |

Table 2: Pin description...continued

| Symbol [1] | Pin | Type | Description |
|--------------------------|-----|------|---|
| GNDD | 64 | - | digital ground |
| AD[5] | 65 | I/O | bit 5 of multiplexed PCI address and data PCI pad; 3.3 V signaling |
| AD[4] | 66 | I/O | bit 4 of multiplexed PCI address and data PCI pad; 3.3 V signaling |
| AD[3] | 67 | I/O | bit 3 of multiplexed PCI address and data PCI pad; 3.3 V signaling |
| AD[2] | 68 | I/O | bit 2 of multiplexed PCI address and data PCI pad; 3.3 V signaling |
| AD[1] | 69 | I/O | bit 1 of multiplexed PCI address and data PCI pad; 3.3 V signaling |
| AD[0] | 70 | I/O | bit 0 of multiplexed PCI address and data PCI pad; 3.3 V signaling |
| V _{CC(I/O)} | 71 | - | 3.3 V supply voltage; used to power pads; add a 100 nF decoupling capacitor |
| GNDA | 72 | - | analog ground |
| AUX1V8 | 73 | - | 1.8 V auxiliary output voltage; only for voltage conditioning; cannot be used to supply power to external components; add a 100 nF decoupling capacitor |
| XTAL1 | 74 | AI | crystal oscillator input; this can also be a 12 MHz clock input |
| XTAL2 | 75 | AO | crystal oscillator output (12 MHz); leave open when clock is used |
| GNDD | 76 | - | digital ground |
| V _{CC(I/O)_AUX} | 77 | - | 3.3 V auxiliary supply voltage; used to power pads; add a 100 nF decoupling capacitor |
| OC1_N | 78 | I | overcurrent sense input for the USB downstream port 1 (digital) 3.3 V input pad; push-pull; CMOS |
| PWE1_N | 79 | O | power enable for the USB downstream port 1 3.3 V output pad; 3 ns slew rate control; CMOS; open-drain |
| GNDA | 80 | - | analog ground |
| RREF | 81 | AI/O | analog connection for the external resistor (12 kΩ ± 1 %) |
| GNDA | 82 | - | analog ground |
| DM1 | 83 | AI/O | D-; analog connection for the USB downstream port 1; leave this pin open when not in use |
| GNDA | 84 | - | analog ground |
| DP1 | 85 | AI/O | D+; analog connection for the USB downstream port 1; leave this pin open when not in use |
| V _{DDA_AUX} | 86 | - | auxiliary analog supply voltage; add a 100 nF decoupling capacitor |
| OC2_N | 87 | I | overcurrent sense input for the USB downstream port 2 (digital) 3.3 V input pad; push-pull; CMOS |
| PWE2_N | 88 | O | power enable for the USB downstream port 2 3.3 V output pad; 3 ns slew rate control; CMOS; open-drain |
| GNDA | 89 | - | analog ground |

Table 2: Pin description...continued

| Symbol ^[1] | Pin | Type | Description |
|--------------------------|-----|-------|--|
| DM2 | 90 | A/I/O | D-; analog connection for the USB downstream port 2; leave this pin open when not in use |
| GNDA | 91 | - | analog ground |
| DP2 | 92 | A/I/O | D+; analog connection for the USB downstream port 2; leave this pin open when not in use |
| V _{DDA_AUX} | 93 | - | auxiliary analog supply voltage; add a 100 nF decoupling capacitor |
| GNDD | 94 | - | digital ground |
| GNDD | 95 | - | digital ground |
| SCL | 96 | I/O | I ² C-bus clock; pull-up to 3.3 V through a 10 kΩ resistor ^[2] I ² C-bus pad; clock signal |
| SDA | 97 | I/O | I ² C-bus data; pull-up to 3.3 V through a 10 kΩ resistor ^[2] I ² C-bus pad; data signal |
| V _{CC(I/O)_AUX} | 98 | - | 3.3 V auxiliary supply voltage; used to power pads; add a 100 nF decoupling capacitor |
| PME# | 99 | O | PCI Power Management Event; used by a device to request a change in the device or system power state PCI pad; 3.3 V signaling; open-drain |
| V _{CC(I/O)_AUX} | 100 | - | 3.3 V auxiliary supply voltage; used to power pads; add a 100 nF decoupling capacitor |

[1] Symbol names ending with # represent active LOW signals for PCI pins, for example: NAME#. Symbol names ending with underscore N represent active LOW signals for USB pins, for example: NAME_N.

[2] Connect to ground if I²C-bus is not used.

7. Functional description

7.1 OHCI Host Controller

An OHCI Host Controller per port transfers data to devices at the Original USB defined bit rate of 12 Mbit/s or 1.5 Mbit/s.

7.2 EHCI Host Controller

The EHCI Host Controller transfers data to a Hi-Speed USB compliant device at the Hi-Speed USB defined bit rate of 480 Mbit/s. When the EHCI Host Controller has the ownership of a port, the OHCI Host Controllers are not allowed to modify the port register. All additional port bit definitions required for the Enhanced Host Controller are not visible to the OHCI Host Controller.

7.3 Dynamic port-routing logic

The port-routing feature allows sharing of the same physical downstream ports between the Original USB Host Controller and the Hi-Speed USB Host Controller. This requirement of the *Enhanced Host Controller Interface Specification for Universal Serial Bus Rev. 1.0* provides ports that are multiplexed with the ports of the OHCI.

The EHCI is responsible for the port-routing switching mechanism. Two register bits are used for ownership switching. During power-on and system reset, the default ownership of all downstream ports is the OHCI. The Enhanced Host Controller Driver (HCD) controls the ownership during normal functionality.

7.4 Hi-Speed USB analog transceivers

The Hi-Speed USB analog transceivers directly interface to the USB cables through integrated termination resistors. These transceivers can transmit and receive serial data at all data rates: high-speed (480 Mbit/s), full-speed (12 Mbit/s) and low-speed (1.5 Mbit/s).

7.5 Power management

The ISP1562 provides an advanced power management capability interface that is compliant with *PCI Bus Power Management Interface Specification Rev. 1.1*. Power is controlled and managed by the interaction between drivers and PCI registers.

For a detailed description on power management, see [Section 10](#).

7.6 Phase-Locked Loop (PLL)

A 12 MHz-to-30 MHz and 48 MHz clock multiplier PLL is integrated on-chip. This allows the use of a low-cost 12 MHz crystal, which also minimizes EMI. No external components are required for the PLL to operate.

7.7 Power-On Reset (POR)

Figure 3 shows a possible curve of $V_{CC(I/O)}$ with dips at t_2 to t_3 and t_4 to t_5 . At t_0 , POR will start with 1. At t_1 , the detector passes through the trip level. Another delay will be added before POR drops to 0 to ensure that the length of the generated detector pulse, POR, is large enough to reset asynchronous flip-flops. If the dip is too short (t_4 to $t_5 < 11 \mu s$), POR will not react and will stay LOW.

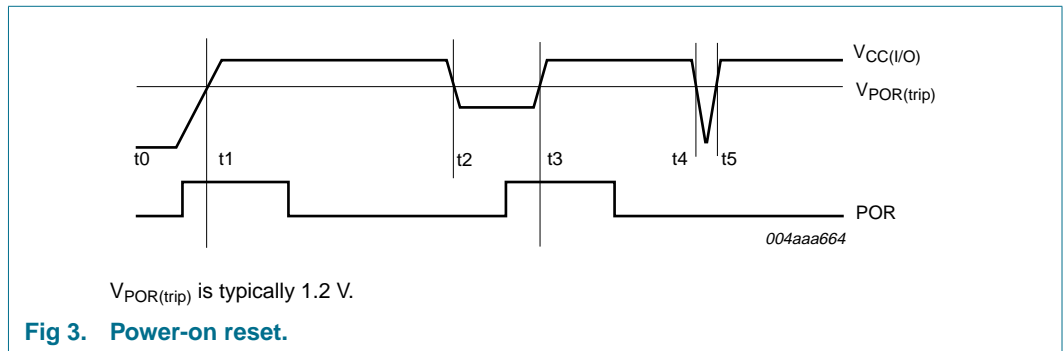

7.8 Power supply

Figure 4 shows the ISP1562 power supply connection.

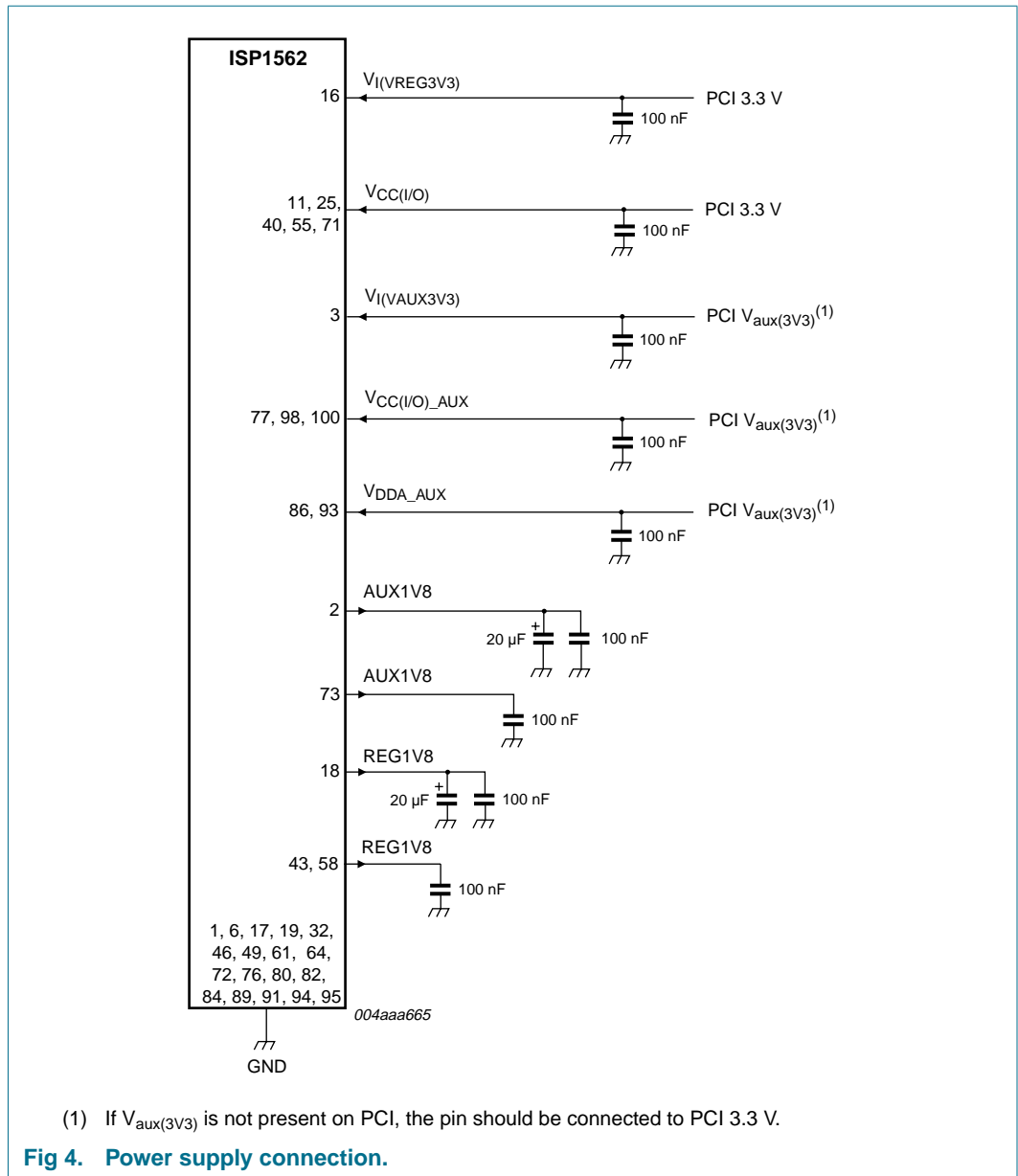

8. PCI

8.1 PCI interface

The PCI interface has three functions. The first function (#0) and the second function (#1) are for the OHCI Host Controllers, and the third function (#2) is for the EHCI Host Controller. All functions support both master and target accesses, and share the same PCI interrupt signal INTA#. These functions provide memory-mapped, addressable operational registers as required in *Open Host Controller Interface Specification for USB Rev. 1.0a* and *Enhanced Host Controller Interface Specification for Universal Serial Bus Rev. 1.0*.

Each function has its own configuration space. The PCI enumerator should allocate the memory address space for each of these functions. Power management is implemented in each PCI function and all power states are provided. This allows the system to achieve low power consumption by switching off the functions that are not required.

8.1.1 PCI configuration space

PCI Local Bus Specification Rev. 2.2 requires that each of the three PCI functions of the ISP1562 provides its own PCI configuration registers, which can vary in size. In addition to the basic PCI configuration header registers, these functions implement capability registers to support power management.

The registers of each of these functions are accessed by the respective driver. [Section 8.2](#) provides a detailed description of the various PCI configuration registers.

8.1.2 PCI initiator and target

A PCI initiator initiates PCI transactions to the PCI bus. A PCI target responds to PCI transactions as a slave. In the case of the ISP1562, the two Open Host Controllers and the Enhanced Host Controller function as both initiators or targets of PCI transactions issued by the host CPU.

All USB Host Controllers have their own operational registers that can be accessed by the system driver software. Drivers use these registers to configure the Host Controller hardware system, issue commands to it, and monitor the status of the current hardware operation. The Host Controller plays the role of a PCI target. All operational registers of the Host Controllers are the PCI transaction targets of the CPU.

Normal USB transfers require the Host Controller to access system memory fields, which are allocated by USB HCDs and PCI drivers. The Host Controller hardware interacts with the HCD by accessing these buffers. The Host Controller works as an initiator in this case and becomes a PCI master.

8.2 PCI configuration registers

The OHCI USB Host Controllers and the EHCI USB Host Controller contain two sets of software-accessible hardware registers: PCI configuration registers and memory-mapped Host Controller registers.

A set of configuration registers is implemented for each of the three PCI functions of the ISP1562, see [Table 3](#).

Remark: In addition to the normal PCI header, from offset index 00h to 3Fh, implementation-specific registers are defined to support power management and function-specific features.

Table 3: PCI configuration space registers of OHCI1, OHCI2 and EHCI

| Address | Bits 31 to 24 | Bits 23 to 16 | Bits 15 to 8 | Bits 7 to 0 | Reset value [1] | | |
|---|-----------------|---------------|-----------------|-------------|---------------------------------|-------------|------------|
| | | | | | Func0 OHCI1 | Func1 OHCI2 | Func2 EHCI |
| PCI configuration header registers | | | | | | | |
| 00h | Device ID[15:0] | | Vendor ID[15:0] | | 1561 1131h | 1561 1131h | 1562 1131h |
| 04h | Status[15:0] | | Command[15:0] | | 0210 0000h | 0210 0000h | 0210 0000h |

Table 3: PCI configuration space registers of OHCI1, OHCI2 and EHCI...continued

| Address | Bits 31 to 24 | Bits 23 to 16 | Bits 15 to 8 | Bits 7 to 0 | Reset value ^[1] | | |
|--|----------------------|------------------|---------------------------|---------------------------|-----------------------------------|-----------------------------------|-----------------------------------|
| | | | | | Func0 OHCI1 | Func1 OHCI2 | Func2 EHCI |
| 08h | Class Code[23:0] | | | Revision ID[7:0] | 0C03 1011h | 0C03 1011h | 0C03 2011h |
| 0Ch | reserved | Header Type[7:0] | Latency Timer[7:0] | CacheLine Size[7:0] | 0080 0000 h | 0080 0000 h | 0080 0000 h |
| 10h | Base Address 0[31:0] | | | | 0000 0000 h | 0000 0000 h | 0000 0000 h |
| 14h | reserved | | | | 0000 0000h | 0000 0000h | 0000 0000h |
| 18h | | | | | | | |
| 1Ch | | | | | | | |
| 20h | | | | | | | |
| 24h | | | | | | | |
| 28h | | | | | | | |
| 2Ch | Subsystem ID[15:0] | | Subsystem Vendor ID[15:0] | | 1561 1131h | 1561 1131h | 1562 1131h |
| 30h | reserved | | | | 0000 0000h | 0000 0000h | 0000 0000h |
| 34h | reserved | | | Capabilities Pointer[7:0] | 0000 00DCh | 0000 00DCh | 0000 00DCh |
| 38h | reserved | | | | 0000 0000h | 0000 0000h | 0000 0000h |
| 3Ch | Max_Lat[7:0] | Min_Gnt[7:0] | Interrupt Pin[7:0] | Interrupt Line[7:0] | 2A01 0100 h | 2A01 0100 h | 1002 0100 h |
| 40h | reserved | | Retry Timeout | TRDY Timeout | 0000 8000 h | 0000 8000 h | 0000 8000 h |
| Enhanced Host Controller-specific PCI registers | | | | | | | |
| 60h | PORTWAKECAP[15:0] | | FLADJ[7:0] | SBRN[7:0] | - | - | 0007 2020 h |
| Power management registers | | | | | | | |
| DCh | PMC[15:0] | | Next_Item_Ptr [7:0] | Cap_ID[7:0] | D282 0001h | D282 0001h | FE82 0001h |
| E0h | Data[7:0] | PMCSR_BSE [7:0] | PMCSR[15:0] | | 0000 XX00 h ^[2] | 0000 XX00 h ^[2] | 0000 XX00 h ^[2] |

[1] Reset values that are highlighted—for example, **0**—indicate read and write accesses; and reset values that are not highlighted—for example, 0—indicate read-only.

[2] See [Section 8.2.3.4](#).

The HCD does not usually interact with the PCI configuration space. The configuration space is used only by the PCI enumerator to identify the USB Host Controller and assign appropriate system resources by reading the Vendor ID (VID) and the Device ID (DID).

8.2.1 PCI configuration header registers

The Enhanced Host Controller implements the normal PCI header register values, except the values for the memory-mapping base address register, serial bus number and Device ID.

8.2.1.1 Vendor ID register

This read-only register identifies the manufacturer of the device. PCI Special Interest Group (PCI-SIG) assigns valid vendor identifiers to ensure the uniqueness of the identifier. The bit description is shown in [Table 4](#).

Table 4: VID - Vendor ID register (address 00h) bit description

Legend: * reset value

| Bit | Symbol | Access | Value | Description |
|---------|-----------|--------|--------|--|
| 15 to 0 | VID[15:0] | R | 1131h* | Vendor ID: This read-only register value is assigned to Philips Semiconductors by PCI-SIG as 1131h. |

8.2.1.2 Device ID register

This is a 2 B read-only register that identifies a particular device. The identifier is allocated by Philips Semiconductors. [Table 5](#) shows the bit description of the register.

Table 5: DID - Device ID register (address 02h) bit description

Legend: * reset value

| Bit | Symbol | Access | Value | Description |
|---------|-----------|--------|-----------------------|--|
| 15 to 0 | DID[15:0] | R | 156Xh* ^[1] | Device ID: This register value is defined by Philips Semiconductors to identify the USB Host Controller IC product. |

[1] X is 1h for OHCI1 and OHCI2; X is 2h for EHCI.

8.2.1.3 Command register

This is a 2 B register that provides coarse control over the ability of a device to generate and respond to PCI cycles. The bit allocation of the Command register is given in [Table 6](#). When logic 0 is written to this register, the device is logically disconnected from the PCI bus for all accesses, except configuration accesses. All devices are required to support this base level of functionality. Individual bits in the Command register may or may not support this base level of functionality.

Table 6: Command register (address 04h) bit allocation

| Bit | 15 | 14 | 13 | 12 | 11 | 10 | 9 | 8 |
|---------------|-------------------------|-----|-------|------|-----|-----|------|-------|
| Symbol | reserved ^[1] | | | | | | FBBE | SERRE |
| Reset | 0 | 0 | 0 | 0 | 0 | 0 | 0 | 0 |
| Access | R/W | R/W | R/W | R/W | R/W | R/W | R/W | R/W |
| Bit | 7 | 6 | 5 | 4 | 3 | 2 | 1 | 0 |
| Symbol | SCTRL | PER | VGAPS | MWIE | SC | BM | MS | IOS |
| Reset | 0 | 0 | 0 | 0 | 0 | 0 | 0 | 0 |
| Access | R | R/W | R | R/W | R | R/W | R/W | R/W |

[1] The reserved bits should always be written with the reset value.

Table 7: Command register (address 04h) bit description

| Bit | Symbol | Description |
|----------|----------|--|
| 15 to 10 | reserved | - |
| 9 | FBBE | <p>Fast Back-to-Back Enable: This bit controls whether a master can do fast back-to-back transactions to various devices. The initialization software must set this bit if all targets are fast back-to-back capable.</p> <p>0 — Fast back-to-back transactions are only allowed to the same agent (value after RST#)</p> <p>1 — The master is allowed to generate fast back-to-back transactions to different agents.</p> |
| 8 | SERRE | <p>SERR# Enable: This bit is an enable bit for the SERR# driver. All devices that have an SERR# pin must implement this bit. Address parity errors are reported only if this bit and the PER bit are logic 1.</p> <p>0 — Disable the SERR# driver</p> <p>1 — Enable the SERR# driver.</p> |
| 7 | SCTRL | <p>Stepping Control: This bit controls whether a device does address and data stepping. Devices that never do stepping must clear this bit. Devices that always do stepping must set this bit. Devices that can do either, must make this bit read and write, and initialize it to logic 1 after RST#.</p> |
| 6 | PER | <p>Parity Error Response: This bit controls the response of a device to parity errors. When the bit is set, the device must take its normal action when a parity error is detected. When the bit is logic 0, the device sets DPE (bit 15 in the Status register) when an error is detected, but does not assert PERR# and continues normal operation. The state of this bit after RST# is logic 0. Devices that check parity must implement this bit. Devices are required to generate parity, even if parity checking is disabled.</p> |
| 5 | VGAPS | <p>VGA Palette Snoop: This bit controls how VGA compatible and graphics devices handle accesses to VGA palette registers.</p> <p>0 — The device should treat palette write accesses like all other accesses.</p> <p>1 — Palette snooping is enabled, that is, the device does not respond to palette register writes and snoops data.</p> <p>VGA compatible devices should implement this bit.</p> |
| 4 | MWIE | <p>Memory Write and Invalidate Enable: This is an enable bit for using the Memory Write and Invalidate command.</p> <p>0 — Memory Writes must be used instead. State after RST# is logic 0.</p> <p>1 — Masters may generate the command.</p> <p>This bit must be implemented by master devices that can generate the Memory Write and Invalidate command.</p> |
| 3 | SC | <p>Special Cycles: Controls the action of a device on Special Cycle operations.</p> <p>0 — Causes the device to ignore all Special Cycle operations. State after RST# is logic 0.</p> <p>1 — Allows the device to monitor Special Cycle operations.</p> |

Table 7: Command register (address 04h) bit description...continued

| Bit | Symbol | Description |
|-----|--------|--|
| 2 | BM | Bus Master: Controls the ability of a device to act as a master on the PCI bus. 0 — Disables the device from generating PCI accesses. State after RST# is logic 0. 1 — Allows the device to behave as a bus master. |
| 1 | MS | Memory Space: Controls the response of a device to Memory Space accesses. 0 — Disables the device response. State after RST# is logic 0. 1 — Allows the device to respond to memory space accesses. |
| 0 | IOS | IO Space: Controls the response of a device to I/O space accesses. 0 — Disables the device response. State after RST# is logic 0. 1 — Allows the device to respond to I/O space accesses. |

8.2.1.4 Status register

The Status register is a 2 B read-only register used to record status information on PCI bus-related events. For bit allocation, see [Table 8](#).

Table 8: Status register (address 06h) bit allocation

| Bit | 15 | 14 | 13 | 12 | 11 | 10 | 9 | 8 |
|---------------|------|----------|------|-----|----------|--------------|---|------|
| Symbol | DPE | SSE | RMA | RTA | STA | DEVSELT[1:0] | | MDPE |
| Reset | 0 | 0 | 0 | 0 | 0 | 0 | 1 | 0 |
| Access | R | R | R | R | R | R | R | R |
| Bit | 7 | 6 | 5 | 4 | 3 | 2 | 1 | 0 |
| Symbol | FBBC | reserved | 66MC | CL | reserved | | | |
| Reset | 0 | 0 | 0 | 1 | 0 | 0 | 0 | 0 |
| Access | R | R | R | R | R | R | R | R |

Table 9: Status register (address 06h) bit description

| Bit | Symbol | Description |
|-----|--------|---|
| 15 | DPE | Detected Parity Error: This bit must be set by the device whenever it detects a parity error, even if the parity error handling is disabled. |
| 14 | SSE | Signaled System Error: This bit must be set whenever the device asserts SERR#. Devices that never assert SERR# do not need to implement this bit. |
| 13 | RMA | Received Master Abort: This bit must be set by a master device whenever its transaction, except for Special Cycle, is terminated with Master-Abort. All master devices must implement this bit. |
| 12 | RTA | Received Target Abort: This bit must be set by a master device whenever its transaction is terminated with Target-Abort. All master devices must implement this bit. |
| 11 | STA | Signaled Target Abort: This bit must be set by a target device whenever it terminates a transaction with Target-Abort. Devices that never signal Target-Abort do not need to implement this bit. |

Table 9: Status register (address 06h) bit description...continued

| Bit | Symbol | Description |
|---------|------------------|---|
| 10 to 9 | DEVSELT [1:0] | <p>DEVSEL Timing: These bits encode the timing of DEVSEL#. There are three allowable timing to assert DEVSEL#:</p> <p>00b — Fast 01b — Medium 10b — Slow 11b — Reserved.</p> <p>These bits are read-only and must indicate the slowest time that a device asserts DEVSEL# for any bus command, except Configuration Read and Configuration Write.</p> |
| 8 | MDPE | <p>Master Data Parity Error: This bit is implemented by bus masters. It is set when the following three conditions are met:</p> <ul style="list-style-type: none"> • The bus agent asserted PERR# itself, on a read; or observed PERR# asserted, on a write. • The agent setting the bit acted as the bus master for the operation in which error occurred. • PER (bit 6 in the Command register) is set. |
| 7 | FBBC | <p>Fast Back-to-Back Capable: This read-only bit indicates whether the target is capable of accepting fast back-to-back transactions when the transactions are not to the same agent. This bit can be set to logic 1, if the device can accept these transactions; and must be set to logic 0 otherwise.</p> |
| 6 | reserved | - |
| 5 | 66MC | <p>66 MHz Capable: This read-only bit indicates whether this device is capable of running at 66 MHz.</p> <p>0 — 33 MHz 1 — 66 MHz.</p> |
| 4 | CL | <p>Capabilities List: This read-only bit indicates whether this device implements the pointer for a new capabilities linked list at offset 34h.</p> <p>0 — No new capabilities linked list is available 1 — The value read at offset 34h is a pointer in configuration space to a linked list of new capabilities.</p> |
| 3 to 0 | reserved | - |

8.2.1.5 Revision ID register

This 1 B read-only register indicates a device-specific revision identifier. The value is chosen by the vendor. This field is a vendor-defined extension of the Device ID. The Revision ID register bit description is given in [Table 10](#).

Table 10: REVID - Revision ID register (address 08h) bit description

Legend: * reset value

| Bit | Symbol | Access | Value | Description |
|--------|------------|--------|-------|--|
| 7 to 0 | REVID[7:0] | R | 11h* | Revision ID: This byte specifies the design revision number of functions. |

8.2.1.6 Class Code register

Class Code is a 24-bit read-only register used to identify the generic function of the device, and in some cases, a specific register-level programming interface. [Table 11](#) shows the bit allocation of the register.

The Class Code register is divided into three byte-size fields. The upper byte is a base class code that broadly classifies the type of function the device performs. The middle byte is a sub-class code that identifies more specifically the function of the device. The lower byte identifies a specific register-level programming interface, if any, so that device-independent software can interact with the device.

Table 11: Class Code register (address 09h) bit allocation

| | | | | | | | | |
|---------------|--------------------|-----------|-----------|-----------|-----------|-----------|-----------|-----------|
| Bit | 23 | 22 | 21 | 20 | 19 | 18 | 17 | 16 |
| Symbol | BCC[7:0] | | | | | | | |
| Reset | 0Ch | | | | | | | |
| Access | R | R | R | R | R | R | R | R |
| Bit | 15 | 14 | 13 | 12 | 11 | 10 | 9 | 8 |
| Symbol | SCC[7:0] | | | | | | | |
| Reset | 03h | | | | | | | |
| Access | R | R | R | R | R | R | R | R |
| Bit | 7 | 6 | 5 | 4 | 3 | 2 | 1 | 0 |
| Symbol | RLPI[7:0] | | | | | | | |
| Reset | X0h ^[1] | | | | | | | |
| Access | R | R | R | R | R | R | R | R |

[1] X is 1h for OHCI1 and OHCI2; X is 2h for EHCI.

Table 12: Class Code register (address 09h) bit description

| Bit | Symbol | Description |
|------------|---------------|--|
| 23 to 16 | BCC[7:0] | Base Class Code: 0Ch is the base class code assigned to this byte. It implies a serial bus controller. |
| 15 to 8 | SCC[7:0] | Sub-Class Code: 03h is the sub-class code assigned to this byte. It implies the USB Host Controller. |
| 7 to 0 | RLPI[7:0] | Register-Level Programming Interface: 10h is the programming interface code assigned to OHCI, which is USB 1.1 specification compliant. 20h is the programming interface code assigned to EHCI, which is USB 2.0 specification compliant. |

8.2.1.7 CacheLine Size register

The CacheLine Size register is a read and write single-byte register that specifies the system CacheLine size in units of DWords. This register must be implemented by master devices that can generate the Memory Write and Invalidate command. The value in this register is also used by master devices to determine whether to use Read, Read Line or Read Multiple command to access the memory.

Slave devices that want to allow memory bursting using a CacheLine-wrap addressing mode must implement this register to know when a burst sequence wraps to the beginning of the CacheLine.

This field must be initialized to logic 0 on activation of RST#. [Table 13](#) shows the bit description of the CacheLine Size register.

Table 13: CLS - CacheLine Size register (address 0Ch) bit description

Legend: * reset value

| Bit | Symbol | Access | Value | Description |
|--------|----------|--------|-------|--|
| 7 to 0 | CLS[7:0] | R/W | 00h* | CacheLine Size: This byte identifies the system CacheLine size. |

8.2.1.8 Latency Timer register

This register specifies—in units of PCI bus clocks—the value of the Latency Timer for the PCI bus master. [Table 14](#) shows the bit description of the Latency Timer register.

Table 14: LT - Latency Timer register (address 0Dh) bit description

Legend: * reset value

| Bit | Symbol | Access | Value | Description |
|--------|---------|--------|-------|---|
| 7 to 0 | LT[7:0] | R/W | 00h* | Latency Timer: This byte identifies the latency timer. |

8.2.1.9 Header Type register

The Header Type register identifies the layout of the second part of the predefined header, beginning at byte 10h in configuration space. It also identifies whether the device contains multiple functions. For bit allocation, see [Table 15](#).

Table 15: Header Type register (address 0Eh) bit allocation

| Bit | 7 | 6 | 5 | 4 | 3 | 2 | 1 | 0 |
|--------|-----|---|---|---|---------|---|---|---|
| Symbol | MFD | | | | HT[6:0] | | | |
| Reset | 1 | 0 | 0 | 0 | 0 | 0 | 0 | 0 |
| Access | R | R | R | R | R | R | R | R |

Table 16: Header Type register (address 0Eh) bit description

| Bit | Symbol | Description |
|--------|---------|--|
| 7 | MFD | Multi-Function Device: This bit identifies a multifunction device. 0 — The device has single function. 1 — The device has multiple functions. |
| 6 to 0 | HT[6:0] | Header Type: These bits identify the layout of the part of the predefined header, beginning at byte 10h in configuration space. |

8.2.1.10 Base Address register 0

Power-up software must build a consistent address map before booting the machine to an operating system. This means it must determine how much memory is in the system, and how much address space the I/O controllers in the system require. After determining this information, power-up software can map the I/O controllers into reasonable locations and proceed with system boot. To do this mapping in a device-independent manner, the base registers for this mapping are placed in the predefined header portion of configuration space.

Bit 0 in all Base Address registers is read-only and used to determine whether the register maps into memory or I/O space. Base Address registers that map to memory space must return logic 0 in bit 0. Base Address registers that map to I/O space must return logic 1 in bit 0.

The bit description of the BAR 0 register is given in [Table 17](#).

Table 17: BAR 0 - Base Address register 0 (address 10h) bit description

Legend: * reset value

| Bit | Symbol | Access | Value | Description |
|---------|-------------|--------|----------------|---|
| 31 to 0 | BAR 0[31:0] | R/W | 0000 0000h* | Base Address to Memory-Mapped Host Controller Register Space: The memory size required by OHCI and EHCI are 4 kB and 256 B, respectively. Therefore, BAR 0[31:12] is assigned to the two OHCI ports, and BAR 0[31:8] is assigned to the EHCI port. |

8.2.1.11 Subsystem Vendor ID register

The Subsystem Vendor ID register is used to uniquely identify the expansion board or subsystem where the PCI device resides. This register allows expansion board vendors to distinguish their boards, even though the boards may have the same Vendor ID and Device ID.

Subsystem Vendor IDs are assigned by PCI-SIG to maintain uniqueness. The bit description of the Subsystem Vendor ID register is given in [Table 18](#).

Table 18: SVID - Subsystem Vendor ID register (address 2Ch) bit description

Legend: * reset value

| Bit | Symbol | Access | Value | Description |
|---------|------------|--------|--------|--|
| 15 to 0 | SVID[15:0] | R | 1131h* | Subsystem Vendor ID: 1131h is the subsystem Vendor ID assigned to Philips Semiconductors. |

8.2.1.12 Subsystem ID register

Subsystem ID values are vendor specific. The bit description of the Subsystem ID register is given in [Table 19](#).

Table 19: SID - Subsystem ID register (address 2Eh) bit description

Legend: * reset value

| Bit | Symbol | Access | Value | Description |
|---------|-----------|--------|----------------------------|---|
| 15 to 0 | SID[15:0] | R | 156Xh* [1] | Subsystem ID: For the ISP1562, Philips Semiconductors has defined OHCI functions as 1561h, and the EHCI function as 1562h. |

[1] X is 1h for OHCI1 and OHCI2; X is 2h for EHCI.

8.2.1.13 Capabilities Pointer register

This register is used to point to a linked list of new capabilities implemented by the device. This register is only valid if CL (bit 4 in the Status register) is set. If implemented, bit 1 and bit 0 are reserved and should be set to 00b. Software should mask these bits off before using this register as a pointer in configuration space to the first entry of a linked list of new capabilities. The bit description of the register is given in [Table 20](#).

Table 20: CP - Capabilities Pointer register (address 34h) bit description

Legend: * reset value

| Bit | Symbol | Access | Value | Description |
|--------|---------|--------|-------|--|
| 7 to 0 | CP[7:0] | R | DCh* | Capabilities Pointer: EHCI efficiently manages power using this register. This Power Management register is allocated at offset DCh. Only one Host Controller is needed to manage power in the ISP1562. |

8.2.1.14 Interrupt Line register

This is a 1 B register used to communicate interrupt line routing information. This register must be implemented by any device or device function that uses an interrupt pin. The interrupt allocation is done by the BIOS. The POST software needs to write the routing information to this register because it initializes and configures the system.

The value in this register specifies which input of the system interrupt controller(s) the interrupt pin of the device is connected. This value is used by device drivers and operating systems to determine priority and vector information. Values in this register are system architecture specific. The bit description of the register is given in [Table 21](#).

Table 21: IL - Interrupt Line register (address 3Ch) bit description

Legend: * reset value

| Bit | Symbol | Access | Value | Description |
|--------|---------|--------|-------|--|
| 7 to 0 | IL[7:0] | R/W | 00h* | Interrupt Line: Indicates which IRQ is used to report interrupt from the ISP1562. |

8.2.1.15 Interrupt Pin register

This 1 B register is use to specify which interrupt pin the device or device function uses.

A value of 1h corresponds to INTA#, 2h corresponds to INTB#, 3h corresponds to INTC#, and 4h corresponds to INTD#. Devices or functions that do not use interrupt pin must set this register to logic 0. The bit description is given in [Table 22](#).

Table 22: IP - Interrupt Pin register (address 3Dh) bit description

Legend: * reset value

| Bit | Symbol | Access | Value | Description |
|--------|---------|--------|-------|---|
| 7 to 0 | IP[7:0] | R | 01h* | Interrupt Pin: INTA# is the default interrupt pin used by the ISP1562. |

8.2.1.16 Min_Gnt and Max_Lat registers

The Minimum Grant (Min_Gnt) and Maximum Latency (Max_Lat) registers are used to specify the desired settings of the device for latency timer values. For both registers, the value specifies a period of time in units of 250 ns. Logic 0 indicates that the device has no major requirements for setting latency timers.

The Min_Gnt register bit description is given in [Table 23](#).

Table 23: Min_Gnt - Minimum Grant register (address 3Eh) bit description

Legend: * reset value

| Bit | Symbol | Access | Value | Description |
|--------|---------------|--------|--------------------------|--|
| 7 to 0 | MIN_GNT [7:0] | R | 0Xh* [1] | Min_Gnt: It is used to specify how long a burst period the device needs, assuming a clock rate of 33 MHz. |

[1] X is 1h for OHCI1 and OHCI2; X is 2h for EHCI.

The Max_Lat register bit description is given in [Table 24](#).

Table 24: Max_Lat - Maximum Latency register (address 3Fh) bit description

Legend: * reset value

| Bit | Symbol | Access | Value | Description |
|--------|------------------|--------|----------|---|
| 7 to 0 | MAX_LAT [7:0] | R | XXh* [1] | Max_Lat: It is used to specify how often the device needs to gain access to the PCI bus. |

[1] XX is 2Ah for OHCI1 and OHCI2; XX is 10h for EHCI.

8.2.1.17 TRDY Timeout register

This is a read and write register at address 40h. The default and recommended value is 00h—TRDY timeout disabled. This value can, however, be modified. It is an implementation-specific register, and not a standard PCI configuration register.

The TRDY timer is 13 bits—the lower 5 bits are fixed as logic 0, and the upper 8 bits are determined by the TRDY Timeout register value. The timeout is calculated by multiplying the 13-bit timer with the PCI CLK cycle time.

This register determines the maximum TRDY delay without asserting the UE (Unrecoverable Error) bit. If TRDY is longer than the delay determined by this register value, then the UE bit will be set.

8.2.1.18 Retry Timeout register

The default value of this read and write register is 80h, and is located at address 41h. This value can, however, be modified. Programming this register as 00h means that retry timeout is disabled. This is an implementation-specific register, and not a standard PCI configuration register.

The timeout is determined by multiplying the register value with the PCI CLK cycle time. This register determines the maximum number of PCI retries before the UE bit is set. If the number of retries is longer than the delay determined by this register value, then the UE bit will be set.

8.2.2 Enhanced Host Controller-specific PCI registers

In addition to the PCI configuration header registers, EHCI needs some additional PCI configuration space registers to indicate the serial bus release number, downstream port wake-up event capability, and adjust the USB bus frame length for Start-of-Frame (SOF). The EHCI-specific PCI registers are given in [Table 25](#).

Table 25: EHCI-specific PCI registers

| Offset | Register |
|------------|------------------------------------|
| 60h | Serial Bus Release Number (SBRN) |
| 61h | Frame Length Adjustment (FLADJ) |
| 62h to 63h | Port Wake Capability (PORTWAKECAP) |

8.2.2.1 SBRN register

The Serial Bus Release Number (SBRN) register is a 1 B register, and the bit description is given in [Table 26](#). This register contains the release number of the USB specification with which this USB Host Controller module is compliant.

Table 26: SBRN - Serial Bus Release Number register (address 60h) bit description

Legend: * reset value

| Bit | Symbol | Access | Value | Description |
|--------|-----------|--------|-------|--|
| 7 to 0 | SBRN[7:0] | R | 20h* | Serial Bus Specification Release Number: This register value is to identify Serial Bus Specification Rev. 2.0. All other combinations are reserved. |

8.2.2.2 FLADJ register

This feature is used to adjust any offset from the clock source that generates the clock that drives the SOF counter. When a new value is written to these six bits, the length of the frame is adjusted. The bit allocation of the Frame Length Adjustment (FLADJ) register is given in [Table 27](#).

Table 27: FLADJ - Frame Length Adjustment register (address 61h) bit allocation

| Bit | 7 | 6 | 5 | 4 | 3 | 2 | 1 | 0 |
|--------|-------------------------|-----|------------|-----|-----|-----|-----|-----|
| Symbol | reserved ^[1] | | FLADJ[5:0] | | | | | |
| Reset | 0 | 0 | 1 | 0 | 0 | 0 | 0 | 0 |
| Access | R/W | R/W | R/W | R/W | R/W | R/W | R/W | R/W |

[1] The reserved bits should always be written with the reset value.

Table 28: FLADJ - Frame Length Adjustment register (address 61h) bit description

| Bit | Symbol | Description |
|--------|------------|---|
| 7 to 6 | reserved | - |
| 5 to 0 | FLADJ[5:0] | Frame Length Timing Value: Each decimal value change to this register corresponds to 16 high-speed bit times. The SOF cycle time—number of SOF counter clock periods to generate a SOF micro frame length—is equal to 59488 + value in this field. The default value is decimal 32 (20h), which gives a SOF cycle time of 60000. |
| | | FLADJ value |
| | | SOF cycle time (480 MHz) |
| | | 0 (00h) |
| | | 59488 |
| | | 1 (01h) |
| | | 59504 |
| | | 2 (02h) |
| | | 59520 |
| | | : |
| | | : |
| | | 31 (1Fh) |
| | | 59984 |
| | | 32 (20h) |
| | | 60000 |
| | | : |
| | | : |
| | | 62 (3Eh) |
| | | 60480 |
| | | 63 (3Fh) |
| | | 60496 |

8.2.2.3 PORTWAKECAP register

Port Wake Capability (PORTWAKECAP) is a 2 B register used to establish a policy about which ports are for wake events; see [Table 29](#). Bit positions 15 to 1 in the mask correspond to a physical port implemented on the current EHCI controller. Logic 1 in a bit position indicates that a device connected below the port can be enabled as a wake-up device and the port may be enabled for disconnect or connect, or overcurrent events as wake-up events. This is an information only mask register. The bits in this register do not

affect the actual operation of the EHCI Host Controller. The system-specific policy can be established by BIOS initializing this register to a system-specific value. The system software uses the information in this register when enabling devices and ports for remote wake-up.

Table 29: PORTWAKECAP - Port Wake Capability register (address 62h) bit description

Legend: * reset value

| Bit | Symbol | Access | Value | Description |
|---------|-----------------------|--------|--------|--|
| 15 to 0 | PORTWAKECAP [15:0] | R/W | 0007h* | Port Wake-Up Capability Mask: EHCI does not implement this feature. |

8.2.3 Power management registers

Table 30: Power Management registers

| Offset | Register |
|----------------------------------|--|
| Value read from address 34h + 0h | Capability Identifier (Cap_ID) |
| Value read from address 34h + 1h | Next Item Pointer (Next_Item_Ptr) |
| Value read from address 34h + 2h | Power Management Capabilities (PMC) |
| Value read from address 34h + 4h | Power Management Control/Status (PMCSR) |
| Value read from address 34h + 6h | Power Management Control/Status PCI-to-PCI Bridge Support Extensions (PMCSR_BSE) |
| Value read from address 34h + 7h | Data |

8.2.3.1 Cap_ID register

The Capability Identifier (Cap_ID) register when read by the system software as 01h indicates that the data structure currently being pointed to is the PCI Power Management data structure. Each function of a PCI device may have only one item in its capability list with Cap_ID set to 01h. The bit description of the register is given in [Table 31](#).

Table 31: Cap_ID - Capability Identifier register bit description

Address: Value read from address 34h + 0h

Legend: * reset value

| Bit | Symbol | Access | Value | Description |
|--------|-------------|--------|-------|---|
| 7 to 0 | CAP_ID[7:0] | R | 01h* | ID: This field when 01h identifies the linked list item as being PCI Power Management registers. |

8.2.3.2 Next_Item_Ptr register

The Next Item Pointer (Next_Item_Ptr) register describes the location of the next item in the function's capability list. The value given is an offset into the function's PCI configuration space. If the function does not implement any other capabilities defined by the PCI-SIG for inclusion in the capabilities list, or if power management is the last item in the list, then this register must be set to 00h. See [Table 32](#).

Table 32: Next_Item_Ptr - Next Item Pointer register bit description

Address: Value read from address 34h + 1h

Legend: * reset value

| Bit | Symbol | Access | Value | Description |
|--------|--------------------|--------|-------|---|
| 7 to 0 | NEXT_ITEM_PTR[7:0] | R | 00h* | Next Item Pointer: This field provides an offset into the function's PCI configuration space, pointing to the location of the next item in the function's capability list. If there are no additional items in the capabilities list, this register is set to 00h. |

8.2.3.3 PMC register

The Power Management Capabilities (PMC) register is a 2 B register, and the bit allocation is given in [Table 33](#). This register provides information on the capabilities of the function related to power management.

Table 33: PMC - Power Management Capabilities register bit allocation

Address: Value read from address 34h + 2h

| Bit | 15 | 14 | 13 | 12 | 11 | 10 | 9 | 8 |
|---------------|------------|----|------------------|----------|------------------|------------------|------|-------|
| Symbol | PME_S[4:0] | | | | | D2_S | D1_S | AUX_C |
| Reset | 1 | 1 | X ^[1] | 1 | X ^[1] | X ^[1] | 1 | 0 |
| Access | R | R | R | R | R | R | R | R |
| Bit | 7 | 6 | 5 | 4 | 3 | 2 | 1 | 0 |
| Symbol | AUX_C[1:0] | | DSI | reserved | PMI | VER[2:0] | | |
| Reset | 1 | 0 | 0 | 0 | 0 | 0 | 1 | 0 |
| Access | R | R | R | R | R | R | R | R |

[1] X is 0 for OHCI1 and OHCI2; X is 1 for EHCI.

Table 34: PMC - Power Management Capabilities register bit description

Address: Value read from address 34h + 2h

| Bit | Symbol | Description |
|----------|-------------|---|
| 15 to 11 | PME_S [4:0] | PME_Support: These bits indicate the power states in which the function may assert PME#. Logic 0 for any bit indicates that the function is not capable of asserting the PME# signal while in that power state. PME_S[0] — PME# can be asserted from D0 PME_S[1] — PME# can be asserted from D1 PME_S[2] — PME# can be asserted from D2 PME_S[3] — PME# can be asserted from D3 _{hot} PME_S[4] — PME# can be asserted from D3 _{cold} . |
| 10 | D2_S | D2_Support: If this bit is logic 1, this function supports the D2 Power Management State. Functions that do not support D2 must always return logic 0 for this bit. |
| 9 | D1_S | D1_Support: If this bit is logic 1, this function supports the D1 Power Management State. Functions that do not support D1 must always return logic 0 for this bit. |

Table 34: PMC - Power Management Capabilities register bit description...continued

Address: Value read from address 34h + 2h

| Bit | Symbol | Description |
|--------|-------------|--|
| 8 to 6 | AUX_C [2:0] | <p>Aux_Current: This three-bit field reports the $V_{aux(3V3)}$ auxiliary current requirements for the PCI function.</p> <p>If the Data register is implemented by this function:</p> <ul style="list-style-type: none"> • A read from this field needs to return a value of 000b. • The Data register takes precedence over this field for $V_{aux(3V3)}$ current requirement reporting. <p>If the PME# generation from D3_{cold} is not supported by the function (PMC[15] = 0), this field must return a value of 000b when read.</p> <p>For functions that support PME# from D3_{cold} and do not implement the Data register, the bit assignments corresponding to the maximum current required for $V_{aux(3V3)}$ are:</p> <p>111b — 375 mA 110b — 320 mA 101b — 270 mA 100b — 220 mA 011b — 160 mA 010b — 100 mA 001b — 55 mA 000b — 0 (self powered).</p> |
| 5 | DSI | <p>Device Specific Initialization: This bit indicates whether special initialization of this function is required, beyond the standard PCI configuration header, before the generic class device driver is able to use it.</p> <p>This bit is not used by some operating systems. For example, Microsoft Windows and Windows NT do not use this bit to determine whether to use D3. Instead, it is determined using the capabilities of the driver.</p> <p>Logic 1 indicates that the function requires a device-specific initialization sequence, following transition to D0 un-initialized state.</p> |
| 4 | reserved | - |
| 3 | PMI | <p>PME Clock:</p> <p>0 — Indicates that no PCI clock is required for the function to generate PME#.</p> <p>1 — Indicates that the function relies on the presence of the PCI clock for the PME# operation.</p> <p>Functions that do not support the PME# generation in any state must return logic 0 for this field.</p> |
| 2 to 0 | VER[2:0] | <p>Version: A value of 010b indicates that this function complies with <i>PCI Bus Power Management Interface Specification Rev. 1.1</i>.</p> |

8.2.3.4 PMCSR register

The Power Management Control/Status (PMCSR) register is a 2 B register used to manage the power management state of the PCI function, as well as to allow and monitor Power Management Events (PMEs). The bit allocation of the register is given in [Table 35](#).

Table 35: PMCSR - Power Management Control/Status register bit allocation

Address: Value read from address 34h + 4h

| Bit | 15 | 14 | 13 | 12 | 11 | 10 | 9 | 8 |
|--------|--------------|---------|-----|----------|-----|-----|---------|-------|
| Symbol | PMES | DS[1:0] | | D_S[3:0] | | | | PMEE |
| Reset | X [1] | 0 | 0 | 0 | 0 | 0 | 0 | X [1] |
| Access | R/W | R | R | R/W | R/W | R/W | R/W | R/W |
| Bit | 7 | 6 | 5 | 4 | 3 | 2 | 1 | 0 |
| Symbol | reserved [2] | | | | | | PS[1:0] | |
| Reset | 0 | 0 | 0 | 0 | 0 | 0 | 0 | 0 |
| Access | R/W | R/W | R/W | R/W | R/W | R/W | R/W | R/W |

[1] Sticky bit, if the function supports PME# from D3_{cold}, then X is indeterminate at the time of initial operating system boot; X is 0 if the function does not support PME# from D3_{cold}.

[2] The reserved bits should always be written with the reset value.

Table 36: PMCSR - Power Management Control/Status register bit description

Address: Value read from address 34h + 4h

| Bit | Symbol | Description |
|----------|-----------|---|
| 15 | PMES | PME Status: This bit is set when the function normally asserts the PME# signal independent of the state of the PMEE bit. Writing logic 1 to this bit clears it and causes the function to stop asserting PME#, if enabled. Writing logic 0 has no effect. This bit defaults to logic 0, if the function does not support the PME# generation from D3 _{cold} . If the function supports the PME# generation from D3 _{cold} , then this bit is sticky and must be explicitly cleared by the operating system each time the operating system is initially loaded. |
| 14 to 13 | DS[1:0] | Data Scale: This two-bit read-only field indicates the scaling factor when interpreting the value of the Data register. The value and meaning of this field vary, depending on which data value is selected by the D_S field. This field is a required component of the Data register (offset 7) and must be implemented, if the Data register is implemented. If the Data register is not implemented, this field must return 00b when PMCSR is read. |
| 12 to 9 | D_S [3:0] | Data_Select: This four-bit field selects the data that is reported through the Data register and the D_S field. This field is a required component of the Data register (offset 7) and must be implemented, if the Data register is implemented. If the Data register is not implemented, this field must return 00b when PMCSR is read. |

Table 36: PMCSR - Power Management Control/Status register bit description...continued
 Address: Value read from address 34h + 4h

| Bit | Symbol | Description |
|--------|----------|---|
| 8 | PMEE | PME Enabled: Logic 1 allows the function to assert PME#. When it is logic 0, PME# assertion is disabled. This bit defaults to logic 0, if the function does not support the PME# generation from D3 _{cold} . If the function supports PME# from D3 _{cold} , then this bit is sticky and must be explicitly cleared by the operating system each time the operating system is initially loaded. |
| 7 to 2 | reserved | - |
| 1 to 0 | PS[1:0] | Power State: This two-bit field is used to determine the current power state of the EHCI function and to set the function into a new power state. The definition of the field values is given as: 00b — D0 01b — D1 10b — D2 11b — D3 _{hot} . If the software attempts to write an unsupported, optional state to this field, the write operation must complete normally on the bus; however, the data is discarded and no status change occurs. |

8.2.3.5 PMCSR_BSE register

The PMCSR PCI-to-PCI Bridge Support Extensions (PMCSR_BSE) register supports PCI bridge-specific functionality and is required for all PCI-to-PCI bridges. The bit allocation of this register is given in [Table 37](#).

Table 37: PMCSR_BSE - PMCSR PCI-to-PCI Bridge Support Extensions register bit allocation

Address: Value read from address 34h + 6h

| Bit | 7 | 6 | 5 | 4 | 3 | 2 | 1 | 0 |
|--------|---------|--------|----------|---|---|---|---|---|
| Symbol | BPCC_EN | B2_B3# | reserved | | | | | |
| Reset | 0 | 0 | 0 | 0 | 0 | 0 | 0 | 0 |
| Access | R | R | R | R | R | R | R | R |

Table 38: PMCSR_BSE - PMCSR PCI-to-PCI Bridge Support Extensions register bit description

Address: Value read from address 34h + 6h

| Bit | Symbol | Description |
|--------|----------|--|
| 7 | BPCC_EN | <p>Bus Power/Clock Control Enable:</p> <p>1 — Indicates that the bus power or clock control mechanism as defined in Table 39 is enabled</p> <p>0 — Indicates that the bus or power control policies as defined in Table 39 are disabled.</p> <p>When the Bus Power or Clock Control mechanism is disabled, the bridge's PMCSR Power State (PS) field cannot be used by the system software to control the power or clock of the bridge's secondary bus.</p> |
| 6 | B2_B3# | <p>B2/B3 support for D3_{hot}: The state of this bit determines the action that is to occur as a direct result of programming the function to D3_{hot}.</p> <p>1 — Indicates that when the bridge function is programmed to D3_{hot}, its secondary bus's PCI clock will be stopped (B2).</p> <p>0 — Indicates that when the bridge function is programmed to D3_{hot}, its secondary bus will have its power removed (B3).</p> <p>This bit is only meaningful if bit 7 (BPCC_EN) is logic 1.</p> |
| 5 to 0 | reserved | - |

Table 39: PCI bus power and clock control

| Originating device's bridge PM state | Secondary bus PM state | Resultant actions by bridge (either direct or indirect) |
|--------------------------------------|------------------------|--|
| D0 | B0 | none |
| D1 | B1 | none |
| D2 | B2 | clock stopped on secondary bus |
| D3 _{hot} | B2, B3 | clock stopped and PCI V _{CC} removed from secondary bus (B3 only); for definition of B2_B3#, see Table 38 . |
| D3 _{cold} | B3 | none |

8.2.3.6 Data register

The Data register is an optional, 1 B register that provides a mechanism for the function to report state dependent operating data, such as power consumed or heat dissipated.

[Table 40](#) shows the bit description of the register.

Table 40: Data register bit description

Address: Value read from address 34h + 7h

Legend: * reset value

| Bit | Symbol | Access | Value | Description |
|--------|-----------|--------|-------|---|
| 7 to 0 | DATA[7:0] | R | 00h* | DATA: This register is used to report the state dependent data requested by the D_S field of the PMCSR register. The value of this register is scaled by the value reported by the DS field of the PMCSR register. |

9. I²C-bus interface

A simple I²C-bus interface is provided in the ISP1562 to read customized vendor ID, product ID and some other configuration bits from an external EEPROM.

The I²C-bus interface is for bidirectional communication between ICs using two serial bus wires: SDA (data) and SCL (clock). Both lines are driven by open-drain circuits and must be connected to the positive supply voltage through pull-up resistors when in use; otherwise, they must be connected to ground.

9.1 Protocol

The I²C-bus protocol defines the following conditions:

- **Bus free:** both SDA and SCL are HIGH
- **START:** a HIGH-to-LOW transition on SDA, while SCL is HIGH
- **STOP:** a LOW-to-HIGH transition on SDA, while SCL is HIGH
- **Data valid:** after a START condition, data on SDA is stable during the HIGH period of SCL; data on SDA may only change while SCL is LOW.

Each device on the I²C-bus has a unique slave address, which the master uses to select a device for access.

The master starts a data transfer using a START condition and ends it by generating a STOP condition. Transfers can only be initiated when the bus is free. The receiver must acknowledge each byte by using a LOW level on SDA during the ninth clock pulse on SCL.

For detailed information, refer to *The I²C-bus Specification, Version 2.1*.

9.2 Hardware connections

The ISP1562 can be connected to an external EEPROM through the I²C-bus interface. The hardware connections are shown in [Figure 5](#).

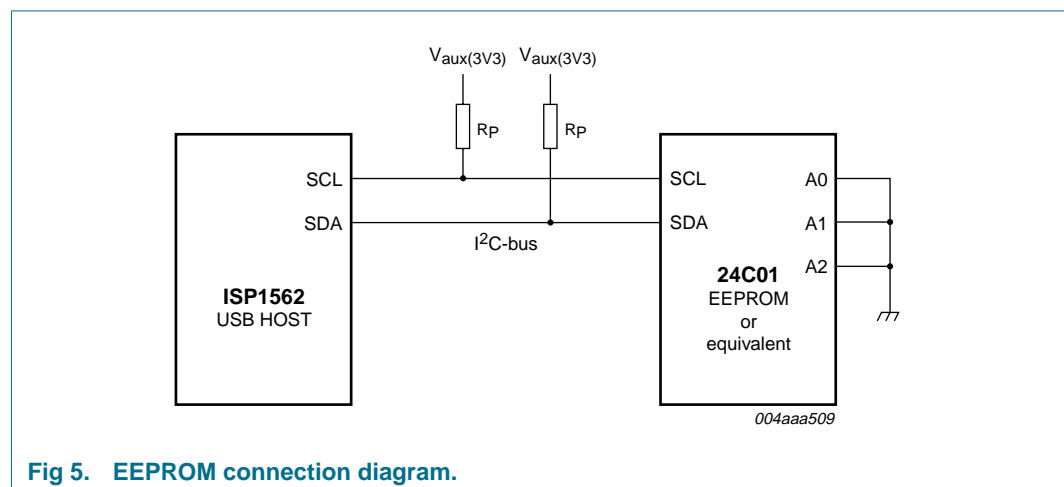
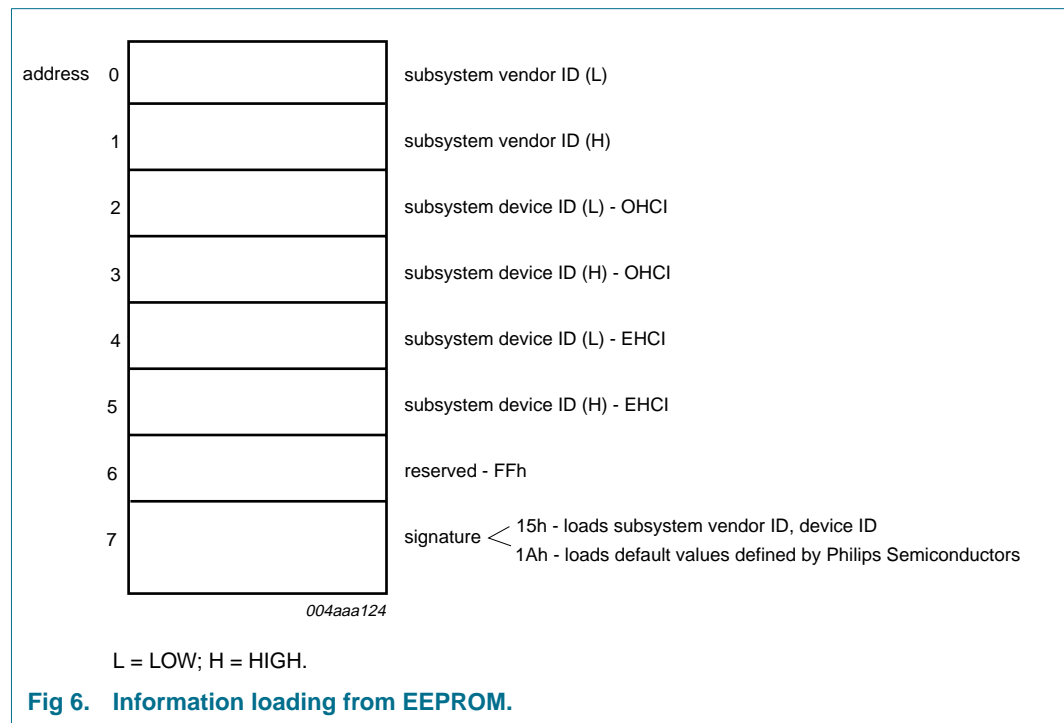

Fig 5. EEPROM connection diagram.

The slave address that the ISP1562 uses to access the EEPROM is 1010000b. Page mode addressing is not supported. Therefore, pins A0, A1 and A2 of the EEPROM must be connected to ground (logic 0).

9.3 Information loading from EEPROM

Figure 6 shows the content of the EEPROM memory. If the EEPROM is not present, the default values of Device ID, Vendor ID, subsystem VID and subsystem DID assigned to Philips Semiconductors by PCI-SIG will be loaded. For default values, see Table 3.



10. Power management

10.1 PCI bus power states

The PCI bus can be characterized by one of the four power management states: B0, B1, B2 and B3.

B0 state (PCI clock = 33 MHz, PCI bus power = on) — This corresponds to the bus being fully operational.

B1 state (PCI clock = intermittent clock operation mode, PCI bus power = on) — When a PCI bus is in B1, PCI V_{CC} is still applied to all devices on the bus. No bus transactions, however, are allowed to take place on the bus. The B1 state indicates a perpetual idle state on the PCI bus.

B2 state (PCI clock = stop, PCI bus power = on) — PCI V_{CC} is still applied on the bus, but the clock is stopped and held in the LOW state.

B3 state (PCI clock = stop, PCI bus power = off) — PCI V_{CC} is removed from all devices on the PCI bus segment.

10.2 USB bus states

Reset state — When the USB bus is in the reset state, the USB system is stopped.

Operational state — When the USB bus is in the active state, the USB system is operating normally.

Suspend state — When the USB bus is in the suspend state, the USB system is stopped.

Resume state — When the USB bus is in the resume state, the USB system is operating normally.

11. USB Host Controller registers

Each Host Controller contains a set of on-chip operational registers that are mapped to un-cached memory of the system addressable space. This memory space must begin on a DWord (32-bit) boundary. The size of the allocated space is defined by the initial value in the Base Address register 0. HCDs must interact with these registers to implement USB functionality.

After the PCI enumeration driver finishes the PCI device configuration, the new base address of these memory-mapped operational registers is defined in BAR 0. The HCD can access these registers by using the address of base address value + offset.

[Table 41](#) contains a list of Host Controller registers.

Table 41: USB Host Controller registers

| Address | OHCI register | Reset value ^[1] | | EHCI register | Reset value ^[1] |
|---------|--------------------|----------------------------|---------------------|------------------------|----------------------------|
| | | Func0 OHCI1 (1P) | Func1 OHCI2 (1P) | | Func2 EHCI (2P) |
| 00h | HcRevision | 0000 0010h | 0000 0010h | CAPLENGTH/HCVERSION | 0100 0020h |
| 04h | HcControl | 0000 0000h | 0000 0000h | HCSPARAMS | 0000 2192h |
| 08h | HcCommandStatus | 0000 0000h | 0000 0000h | HCCPARAMS | 0000 0012h |
| 0Ch | HcInterruptStatus | 0000 0000h | 0000 0000h | HCSP-PORTROUTE1[31:0] | 0000 0010h |
| 10h | HcInterruptEnable | 0000 0000h | 0000 0000h | HCSP-PORTROUTE2[59:32] | 0000 0000h |
| 14h | HcInterruptDisable | 0000 0000h | 0000 0000h | reserved | - |
| 18h | HcHCCA | 0000 0000h | 0000 0000h | reserved | - |
| 1Ch | HcPeriodCurrentED | 0000 0000h | 0000 0000h | reserved | - |
| 20h | HcControlHeadED | 0000 0000h | 0000 0000h | USBCMD | 0008 0000h |
| 24h | HcControlCurrentED | 0000 0000h | 0000 0000h | USBSTS | 0000 1000h |
| 28h | HcBulkHeadED | 0000 0000h | 0000 0000h | USBINTR | 0000 0000h |
| 2Ch | HcBulkCurrentED | 0000 0000h | 0000 0000h | FRINDEX | 0000 0000h |
| 30h | HcDoneHead | 0000 0000h | 0000 0000h | reserved | - |
| 34h | HcFmInterval | 0000 2EDFh | 0000 2EDFh | PERIODICLISTBASE | 0000 0000h |
| 38h | HcFmRemaining | 0000 0000h | 0000 0000h | ASYNCLISTADDR | 0000 0000h |
| 3Ch | HcFmNumber | 0000 0000h | 0000 0000h | reserved | - |
| 40h | HcPeriodicStart | 0000 0000h | 0000 0000h | reserved | - |
| 44h | HcLSThreshold | 0000 0628h | 0000 0628h | reserved | - |
| 48h | HcRhDescriptorA | FF00 0901h | FF00 0901h | reserved | - |

Table 41: USB Host Controller registers...continued

| Address | OHCI register | Reset value [1] | | EHCI register | Reset value [1] |
|---------|-------------------|---------------------|---------------------|---------------|--------------------|
| | | Func0 OHCI1 (1P) | Func1 OHCI2 (1P) | | Func2 EHCI (2P) |
| 4Ch | HcRhDescriptorB | 0002 0000h | 0002 0000h | reserved | - |
| 50h | HcRhStatus | 0000 0000h | 0000 0000h | reserved | - |
| 54h | HcRhPortStatus[1] | 0000 0000h | 0000 0000h | reserved | - |
| 58h | HcRhPortStatus[2] | - | - | reserved | - |
| 5Ch | reserved | - | - | reserved | - |
| 60h | reserved | - | - | CONFIGFLAG | 0000 0000h |
| 64h | reserved | - | - | PORTSC1 | 0000 0000h |
| 68h | reserved | - | - | PORTSC2 | 0000 0000h |
| 6Ch | reserved | - | - | reserved | - |
| 70h | reserved | - | - | reserved | - |

[1] Reset values that are highlighted—for example, 0—are the ISP1562 implementation-specific reset values; and reset values that are not highlighted—for example, 0—are compliant with OHCI and EHCI specifications.

For the OHCI Host Controller, there are only operational registers for the USB operation.

For the Enhanced Host Controller, there are two types of registers: one set of read-only capability registers and one set of read and write operational registers.

11.1 OHCI USB Host Controller operational registers

OHCI HCDs need to communicate with these registers to implement USB data transfers. Based on their functions, these registers are classified into four partitions:

- Control and Status
- Memory Pointer
- Frame Counter
- Root Hub.

11.1.1 HcRevision register

Table 42: HcRevision - Host Controller Revision register bit allocation

Address: Value read from func0 or func1 of address 10h + 00h

| Bit | 31 | 30 | 29 | 28 | 27 | 26 | 25 | 24 |
|--------|----------|----|----|----|----|----|----|----|
| Symbol | reserved | | | | | | | |
| Reset | 0 | 0 | 0 | 0 | 0 | 0 | 0 | 0 |
| Access | R | R | R | R | R | R | R | R |
| Bit | 23 | 22 | 21 | 20 | 19 | 18 | 17 | 16 |
| Symbol | reserved | | | | | | | |
| Reset | 0 | 0 | 0 | 0 | 0 | 0 | 0 | 0 |
| Access | R | R | R | R | R | R | R | R |

| | | | | | | | | |
|---------------|-----------|-----------|-----------|-----------|-----------|-----------|----------|----------|
| Bit | 15 | 14 | 13 | 12 | 11 | 10 | 9 | 8 |
| Symbol | reserved | | | | | | | |
| Reset | 0 | 0 | 0 | 0 | 0 | 0 | 0 | 0 |
| Access | R | R | R | R | R | R | R | R |
| Bit | 7 | 6 | 5 | 4 | 3 | 2 | 1 | 0 |
| Symbol | REV[7:0] | | | | | | | |
| Reset | 0 | 0 | 0 | 1 | 0 | 0 | 0 | 0 |
| Access | R | R | R | R | R | R | R | R |

Table 43: HcRevision - Host Controller Revision register bit description

Address: Value read from func0 or func1 of address 10h + 00h

| Bit | Symbol | Description |
|---------|----------|---|
| 31 to 8 | reserved | - |
| 7 to 0 | REV[7:0] | Revision: This read-only field contains the BCD representation of the version of the HCI specification that is implemented by this Host Controller. For example, a value of 11h corresponds to version 1.1. All of the Host Controller implementations that are compliant with this specification need to have a value of 10h. |

11.1.2 HcControl register

This register defines the operating modes for the Host Controller. All the fields in this register, except for HCFS and RWC, are modified only by the HCD. The bit allocation is given in [Table 44](#).

Table 44: HcControl - Host Controller Control register bit allocation

Address: Value read from func0 or func1 of address 10h + 04h

| | | | | | | | | |
|---------------|-------------------------|-----------|-----------|-----------|-----------|-----------|-----------|-----------|
| Bit | 31 | 30 | 29 | 28 | 27 | 26 | 25 | 24 |
| Symbol | reserved ^[1] | | | | | | | |
| Reset | 0 | 0 | 0 | 0 | 0 | 0 | 0 | 0 |
| Access | R/W | R/W | R/W | R/W | R/W | R/W | R/W | R/W |
| Bit | 23 | 22 | 21 | 20 | 19 | 18 | 17 | 16 |
| Symbol | reserved ^[1] | | | | | | | |
| Reset | 0 | 0 | 0 | 0 | 0 | 0 | 0 | 0 |
| Access | R/W | R/W | R/W | R/W | R/W | R/W | R/W | R/W |
| Bit | 15 | 14 | 13 | 12 | 11 | 10 | 9 | 8 |
| Symbol | reserved ^[1] | | | | | RWE | RWC | IR |
| Reset | 0 | 0 | 0 | 0 | 0 | 0 | 0 | 0 |
| Access | R/W | R/W | R/W | R/W | R/W | R/W | R/W | R/W |
| Bit | 7 | 6 | 5 | 4 | 3 | 2 | 1 | 0 |
| Symbol | HCFS[1:0] | | BLE | CLE | IE | PLE | CBSR[1:0] | |
| Reset | 0 | 0 | 0 | 0 | 0 | 0 | 0 | 0 |
| Access | R/W | R/W | R/W | R/W | R/W | R/W | R/W | R/W |

[1] The reserved bits should always be written with the reset value.

Table 45: HcControl - Host Controller Control register bit description

Address: Value read from func0 or func1 of address 10h + 04h

| Bit | Symbol | Description |
|----------|---------------|---|
| 31 to 11 | reserved | - |
| 10 | RWE | RemoteWakeupEnable: This bit is used by the HCD to enable or disable the remote wake-up feature on detecting upstream resume signaling. When this bit and RD (bit 3) in the HcInterruptStatus register are set, a remote wake-up is signaled to the host system. Setting this bit has no impact on the generation of hardware interrupt. |
| 9 | RWC | RemoteWakeupConnected: This bit indicates whether the Host Controller supports remote wake-up signaling. If remote wake-up is supported and used by the system, it is the responsibility of the system firmware to set this bit during POST. The Host Controller clears the bit on a hardware reset but does not alter it on a software reset. Remote wake-up signaling of the host system is host-bus-specific and is not described in this specification. |
| 8 | IR | InterruptRouting: This bit determines the routing of interrupts generated by events registered in HcInterruptStatus. If clear, all interrupts are routed to the normal host bus interrupt mechanism. If set, interrupts are routed to the System Management Interrupt. The HCD clears this bit on a hardware reset, but it does not alter this bit on a software reset. The HCD uses this bit as a tag to indicate the ownership of the Host Controller. |
| 7 to 6 | HCFS [1:0] | <p>HostControllerFunctionalState for USB:</p> <p>00b — USBRESET</p> <p>01b — USBRESUME</p> <p>10b — USBOPERATIONAL</p> <p>11b — USBSUSPEND.</p> <p>A transition to USBOPERATIONAL from another state causes SOF generation to begin 1 ms later. The HCD may determine whether the Host Controller has begun sending SOFs by reading SF (bit 2) in HcInterruptStatus.</p> <p>This field may be changed by the Host Controller only when in the USBSUSPEND state. The Host Controller may move from the USBSUSPEND state to the USBRESUME state after detecting the resume signaling from a downstream port.</p> <p>The Host Controller enters USBSUSPEND after a software reset; it enters USBRESET after a hardware reset. The latter also resets the Root Hub and asserts subsequent reset signaling to downstream ports.</p> |
| 5 | BLE | BulkListEnable: This bit is set to enable the processing of the bulk list in the next frame. If cleared by the HCD, processing of the bulk list does not occur after the next SOF. The Host Controller checks this bit whenever it wants to process the list. When disabled, the HCD may modify the list. If HcBulkCurrentED is pointing to an Endpoint Descriptor (ED) to be removed, the HCD must advance the pointer by updating HcBulkCurrentED before re-enabling processing of the list. |

Table 45: HcControl - Host Controller Control register bit description...continued

Address: Value read from func0 or func1 of address 10h + 04h

| Bit | Symbol | Description |
|--------|---------------|---|
| 4 | CLE | ControlListEnable: This bit is set to enable the processing of the control list in the next frame. If cleared by the HCD, processing of the control list does not occur after the next SOF. The Host Controller must check this bit whenever it wants to process the list. When disabled, the HCD may modify the list. If HcControlCurrentED is pointing to an ED to be removed, the HCD must advance the pointer by updating HcControlCurrentED before re-enabling processing of the list. |
| 3 | IE | IsochronousEnable: This bit is used by the HCD to enable or disable processing of isochronous EDs. While processing the periodic list in a frame, the Host Controller checks the status of this bit when it finds an isochronous ED (F = 1). If set (enabled), the Host Controller continues processing the EDs. If cleared (disabled), the Host Controller halts processing of the periodic list—which now contains only isochronous EDs—and begins processing the bulk or control lists. Setting this bit is guaranteed to take effect in the next frame and not the current frame. |
| 2 | PLE | PeriodicListEnable: This bit is set to enable the processing of the periodic list in the next frame. If cleared by the HCD, processing of the periodic list does not occur after the next SOF. The Host Controller must check this bit before it starts processing the list. |
| 1 to 0 | CBSR [1:0] | ControlBulkServiceRatio: This specifies the service ratio of control EDs over bulk EDs. Before processing any of the nonperiodic lists, the Host Controller must compare the ratio specified with its internal count on how many nonempty control EDs are processed, in determining whether to continue serving another control ED or switching to bulk EDs. The internal count must be retained when crossing the frame boundary. After a reset, the HCD is responsible to restore this value. 00b — 1 : 1 01b — 2 : 1 10b — 3 : 1 11b — 4 : 1. |

11.1.3 HcCommandStatus register

The HcCommandStatus register is used by the Host Controller to receive commands issued by the HCD. It also reflects the current status of the Host Controller. To the HCD, it appears as a 'write to set' register. The Host Controller must ensure that bits written as logic 1 become set in the register while bits written as logic 0 remain unchanged in the register. The HCD may issue multiple distinct commands to the Host Controller without concern for corrupting previously issued commands. The HCD has normal read access to all bits.

The SOC[1:0] field (bits 17 and 16 in the HcCommandStatus register) indicates the number of frames with which the Host Controller has detected the scheduling overrun error. This occurs when the periodic list does not complete before EOF. When a scheduling overrun error is detected, the Host Controller increments the counter and sets SO (bit 0 in the HcInterruptStatus register).

[Table 46](#) shows the bit allocation of the HcCommandStatus register.

Table 46: HcCommandStatus - Host Controller Command Status register bit allocation

Address: Value read from func0 or func1 of address 10h + 08h

| | | | | | | | | |
|---------------|--------------|-----------|-----------|-----------|-----------|-----------|-----------|-----------|
| Bit | 31 | 30 | 29 | 28 | 27 | 26 | 25 | 24 |
| Symbol | reserved [1] | | | | | | | |
| Reset | 0 | 0 | 0 | 0 | 0 | 0 | 0 | 0 |
| Access | R/W | R/W | R/W | R/W | R/W | R/W | R/W | R/W |
| Bit | 23 | 22 | 21 | 20 | 19 | 18 | 17 | 16 |
| Symbol | reserved [1] | | | | | | SOC[1:0] | |
| Reset | 0 | 0 | 0 | 0 | 0 | 0 | 0 | 0 |
| Access | R/W | R/W | R/W | R/W | R/W | R/W | R/W | R/W |
| Bit | 15 | 14 | 13 | 12 | 11 | 10 | 9 | 8 |
| Symbol | reserved [1] | | | | | | | |
| Reset | 0 | 0 | 0 | 0 | 0 | 0 | 0 | 0 |
| Access | R/W | R/W | R/W | R/W | R/W | R/W | R/W | R/W |
| Bit | 7 | 6 | 5 | 4 | 3 | 2 | 1 | 0 |
| Symbol | reserved [1] | | | | OCR | BLF | CLF | HCR |
| Reset | 0 | 0 | 0 | 0 | 0 | 0 | 0 | 0 |
| Access | R/W | R/W | R/W | R/W | R/W | R/W | R/W | R/W |

[1] The reserved bits should always be written with the reset value.

Table 47: HcCommandStatus - Host Controller Command Status register bit description

Address: Value read from func0 or func1 of address 10h + 08h

| Bit | Symbol | Description |
|----------|----------|--|
| 31 to 18 | reserved | - |
| 17 to 16 | SOC[1:0] | SchedulingOverrunCount: The bit is incremented on each scheduling overrun error. It is initialized to 00b and wraps around at 11b. It must be incremented when a scheduling overrun is detected, even if SO (bit 0 in HcInterruptStatus) is already set. This is used by the HCD to monitor any persistent scheduling problems. |
| 15 to 4 | reserved | - |
| 3 | OCR | OwnershipChangeRequest: This bit is set by an OS HCD to request a change of control of the Host Controller. When set, the Host Controller must set OC (bit 30 in HcInterruptStatus). After the changeover, this bit is cleared and remains so until the next request from the OS HCD. |

Table 47: HcCommandStatus - Host Controller Command Status register bit description...continued

| Bit | Symbol | Description |
|-----|--------|---|
| 2 | BLF | BulkListFilled: This bit is used to indicate whether there are any Transfer Descriptors (TDs) on the bulk list. It is set by the HCD whenever it adds a TD to an ED in the bulk list. When the Host Controller begins to process the head of the bulk list, it checks Bulk-Filled (BF). If BLF is logic 0, the Host Controller does not need to process the bulk list. If BLF is logic 1, the Host Controller needs to start processing the bulk list and set BF to logic 0. If the Host Controller finds a TD on the list, then the Host Controller needs to set BLF to logic 1, causing the bulk list processing to continue. If no TD is found on the bulk list, and if the HCD does not set BLF, then BLF is still logic 0 when the Host Controller completes processing the bulk list and the bulk list processing stops. |
| 1 | CLF | ControlListFilled: This bit is used to indicate whether there are any TDs on the control list. It is set by the HCD whenever it adds a TD to an ED in the control list. When the Host Controller begins to process the head of the control list, it checks CLF. If CLF is logic 0, the Host Controller does not need to process the control list. If Control-Filled (CF) is logic 1, the Host Controller needs to start processing the control list and set CLF to logic 0. If the Host Controller finds a TD on the list, then the Host Controller needs to set CLF to logic 1, causing the control list processing to continue. If no TD is found on the control list, and if the HCD does not set CLF, then CLF is still logic 0 when the Host Controller completes processing the control list and the control list processing stops. |
| 0 | HCR | HostControllerReset: This bit is set by the HCD to initiate a software reset of the Host Controller. Regardless of the functional state of the Host Controller, it moves to the USB SUSPEND state in which most of the operational registers are reset, except those stated otherwise; for example, IR (bit 8) in the HcControl register, and no host bus accesses are allowed. This bit is cleared by the Host Controller on completing the reset operation. The reset operation must be completed within 10 μ s. This bit, when set, should not cause a reset to the Root Hub and no subsequent reset signaling should be asserted to its downstream ports. |

11.1.4 HcInterruptStatus register

This is a 4 B register that provides the status of the events that cause hardware interrupts. The bit allocation of the register is given in [Table 48](#). When an event occurs, the Host Controller sets the corresponding bit in this register. When a bit becomes set, a hardware interrupt is generated, if the interrupt is enabled in the HcInterruptEnable register (see [Table 50](#)) and the MIE (MasterInterruptEnable) bit is set. The HCD may clear specific bits in this register by writing logic 1 to the bit positions to be cleared. The HCD may not set any of these bits. The Host Controller does not clear the bit.

Table 48: HcInterruptStatus - Host Controller Interrupt Status register bit allocation

Address: Value read from func0 or func1 of address 10h + 0Ch

| Bit | 31 | 30 | 29 | 28 | 27 | 26 | 25 | 24 |
|--------|--------------|-----|-----|-----|-----|--------------|-----|-----|
| Symbol | reserved [1] | OC | | | | reserved [1] | | |
| Reset | 0 | 0 | 0 | 0 | 0 | 0 | 0 | 0 |
| Access | R/W | R/W | R/W | R/W | R/W | R/W | R/W | R/W |

| | | | | | | | | |
|---------------|--------------|-----------|-----------|-----------|-----------|-----------|-----------|-----------|
| Bit | 23 | 22 | 21 | 20 | 19 | 18 | 17 | 16 |
| Symbol | reserved [1] | | | | | | | |
| Reset | 0 | 0 | 0 | 0 | 0 | 0 | 0 | 0 |
| Access | R/W | R/W | R/W | R/W | R/W | R/W | R/W | R/W |
| Bit | 15 | 14 | 13 | 12 | 11 | 10 | 9 | 8 |
| Symbol | reserved [1] | | | | | | | |
| Reset | 0 | 0 | 0 | 0 | 0 | 0 | 0 | 0 |
| Access | R/W | R/W | R/W | R/W | R/W | R/W | R/W | R/W |
| Bit | 7 | 6 | 5 | 4 | 3 | 2 | 1 | 0 |
| Symbol | reserved [1] | RHSC | FNO | UE | RD | SF | WDH | SO |
| Reset | 0 | 0 | 0 | 0 | 0 | 0 | 0 | 0 |
| Access | R/W | R/W | R/W | R/W | R/W | R/W | R/W | R/W |

[1] The reserved bits should always be written with the reset value.

Table 49: HcInterruptStatus - Host Controller Interrupt Status register bit description

Address: Value read from func0 or func1 of address 10h + 0Ch

| Bit | Symbol | Description |
|---------|----------|--|
| 31 | reserved | - |
| 30 | OC | OwnershipChange: This bit is set by the Host Controller when HCD sets OCR (bit 3) in the HcCommandStatus register. This event, when unmasked, will always immediately generate a System Management Interrupt (SMI). This bit is forced to logic 0 when the SMI# pin is not implemented. |
| 29 to 7 | reserved | - |
| 6 | RHSC | RootHubStatusChange: This bit is set when the content of HcRhStatus or the content of any of HcRhPortStatus[NumberOfDownstreamPort] has changed. |
| 5 | FNO | FrameNumberOverflow: This bit is set when the MSB of HcFmNumber (bit 15) changes value, or after the HccaFrameNumber is updated. |
| 4 | UE | UnrecoverableError: This bit is set when the Host Controller detects a system error not related to USB. The Host Controller should not proceed with any processing nor signaling before the system error is corrected. The HCD clears this bit after the Host Controller is reset. |
| 3 | RD | ResumeDetected: This bit is set when the Host Controller detects that a device on the USB is asserting resume signaling. This bit is set by the transition from no resume signaling to resume signaling. This bit is not set when the HCD sets the USBRESUME state. |
| 2 | SF | Start-of-Frame: At the start of each frame, this bit is set by the Host Controller and an SOF token is generated at the same time. |
| 1 | WDH | WritebackDoneHead: This bit is immediately set after the Host Controller has written HcDoneHead to HccaDoneHead. Further, updates of HccaDoneHead occur only after this bit is cleared. The HCD should only clear this bit after it has saved the content of HccaDoneHead. |
| 0 | SO | SchedulingOverrun: This bit is set when USB schedules for current frame overruns and after the update of HccaFrameNumber. A scheduling overrun increments the SOC[1:0] field (bits 17 to 16 of HcCommandStatus). |

11.1.5 HcInterruptEnable register

Each enable bit in the HcInterruptEnable register corresponds to an associated interrupt bit in the HcInterruptStatus register. The HcInterruptEnable register is used to control which events generate a hardware interrupt. A hardware interrupt is requested on the host bus if the following conditions occur:

- A bit is set in the HcInterruptStatus register.
- The corresponding bit in the HcInterruptEnable register is set.
- The MIE (MasterInterruptEnable) bit is set.

Writing logic 1 to a bit in this register sets the corresponding bit, whereas writing logic 0 to a bit in this register leaves the corresponding bit unchanged. On a read, the current value of this register is returned. The bit allocation is given in [Table 50](#).

Table 50: HcInterruptEnable - Host Controller Interrupt Enable register bit allocation

Address: Value read from func0 or func1 of address 10h + 10h

| | | | | | | | | |
|---------------|-------------------------|-----------|-------------------------|-----------|-----------|-----------|-----------|-----------|
| Bit | 31 | 30 | 29 | 28 | 27 | 26 | 25 | 24 |
| Symbol | MIE | OC | reserved ^[1] | | | | | |
| Reset | 0 | 0 | 0 | 0 | 0 | 0 | 0 | 0 |
| Access | R/W | R/W | R/W | R/W | R/W | R/W | R/W | R/W |
| Bit | 23 | 22 | 21 | 20 | 19 | 18 | 17 | 16 |
| Symbol | reserved ^[1] | | | | | | | |
| Reset | 0 | 0 | 0 | 0 | 0 | 0 | 0 | 0 |
| Access | R/W | R/W | R/W | R/W | R/W | R/W | R/W | R/W |
| Bit | 15 | 14 | 13 | 12 | 11 | 10 | 9 | 8 |
| Symbol | reserved ^[1] | | | | | | | |
| Reset | 0 | 0 | 0 | 0 | 0 | 0 | 0 | 0 |
| Access | R/W | R/W | R/W | R/W | R/W | R/W | R/W | R/W |
| Bit | 7 | 6 | 5 | 4 | 3 | 2 | 1 | 0 |
| Symbol | reserved ^[1] | RHSC | FNO | UE | RD | SF | WDH | SO |
| Reset | 0 | 0 | 0 | 0 | 0 | 0 | 0 | 0 |
| Access | R/W | R/W | R/W | R/W | R/W | R/W | R/W | R/W |

[1] The reserved bits should always be written with the reset value.

Table 51: HcInterruptEnable - Host Controller Interrupt Enable register bit description

Address: Value read from func0 or func1 of address 10h + 10h

| Bit | Symbol | Description |
|---------|----------|---|
| 31 | MIE | Master Interrupt Enable: 0 — Ignore 1 — Enables interrupt generation by events specified in other bits of this register. |
| 30 | OC | Ownership Change: 0 — Ignore 1 — Enables interrupt generation because of Ownership Change. |
| 29 to 7 | reserved | - |

Table 51: HcInterruptEnable - Host Controller Interrupt Enable register bit description...continued

| Bit | Symbol | Description |
|-----|--------|---|
| 6 | RHSC | Root Hub Status Change: 0 — Ignore 1 — Enables interrupt generation because of Root Hub Status Change. |
| 5 | FNO | Frame Number Overflow: 0 — Ignore 1 — Enables interrupt generation because of Frame Number Overflow. |
| 4 | UE | Unrecoverable Error: 0 — Ignore 1 — Enables interrupt generation because of Unrecoverable Error. |
| 3 | RD | Resume Detect: 0 — Ignore 1 — Enables interrupt generation because of Resume Detect. |
| 2 | SF | Start-of-Frame: 0 — Ignore 1 — Enables interrupt generation because of Start-of-Frame. |
| 1 | WDH | HcDoneHead Writeback: 0 — Ignore 1 — Enables interrupt generation because of HcDoneHead Writeback. |
| 0 | SO | Scheduling Overrun: 0 — Ignore 1 — Enables interrupt generation because of Scheduling Overrun. |

11.1.6 HcInterruptDisable register

Each disable bit in the HcInterruptDisable register corresponds to an associated interrupt bit in the HcInterruptStatus register. The HcInterruptDisable register is coupled with the HcInterruptEnable register. Therefore, writing logic 1 to a bit in this register clears the corresponding bit in the HcInterruptEnable register, whereas writing logic 0 to a bit in this register leaves the corresponding bit in the HcInterruptEnable register unchanged. On a read, the current value of the HcInterruptEnable register is returned.

The register contains 4 B, and the bit allocation is given in [Table 52](#).

Table 52: HcInterruptDisable - Host Controller Interrupt Disable register bit allocation

Address: Value read from func0 or func1 of address 10h + 14h

| Bit | 31 | 30 | 29 | 28 | 27 | 26 | 25 | 24 |
|--------|-------------------------|-----|-------------------------|-----|-----|-----|-----|-----|
| Symbol | MIE | OC | reserved ^[1] | | | | | |
| Reset | 0 | 0 | 0 | 0 | 0 | 0 | 0 | 0 |
| Access | R/W | R/W | R/W | R/W | R/W | R/W | R/W | R/W |
| Bit | 23 | 22 | 21 | 20 | 19 | 18 | 17 | 16 |
| Symbol | reserved ^[1] | | | | | | | |
| Reset | 0 | 0 | 0 | 0 | 0 | 0 | 0 | 0 |
| Access | R/W | R/W | R/W | R/W | R/W | R/W | R/W | R/W |

| Bit | 15 | 14 | 13 | 12 | 11 | 10 | 9 | 8 |
|--------|--------------|------|-----|-----|-----|-----|-----|-----|
| Symbol | reserved [1] | | | | | | | |
| Reset | 0 | 0 | 0 | 0 | 0 | 0 | 0 | 0 |
| Access | R/W | R/W | R/W | R/W | R/W | R/W | R/W | R/W |
| Bit | 7 | 6 | 5 | 4 | 3 | 2 | 1 | 0 |
| Symbol | reserved [1] | RHSC | FNO | UE | RD | SF | WDH | SO |
| Reset | 0 | 0 | 0 | 0 | 0 | 0 | 0 | 0 |
| Access | R/W | R/W | R/W | R/W | R/W | R/W | R/W | R/W |

[1] The reserved bits should always be written with the reset value.

Table 53: HcInterruptDisable - Host Controller Interrupt Disable register bit description
 Address: Value read from func0 or func1 of address 10h + 14h

| Bit | Symbol | Description |
|---------|----------|--|
| 31 | MIE | Master Interrupt Enable: 0 — Ignore 1 — Disables interrupt generation because of events specified in other bits of this register. This field is set after a hardware or software reset. Interrupts are disabled. |
| 30 | OC | Ownership Change: 0 — Ignore 1 — Disables interrupt generation because of Ownership Change. |
| 29 to 7 | reserved | - |
| 6 | RHSC | Root Hub Status Change: 0 — Ignore 1 — Disables interrupt generation because of Root Hub Status Change. |
| 5 | FNO | Frame Number Overflow: 0 — Ignore 1 — Disables interrupt generation because of Frame Number Overflow. |
| 4 | UE | Unrecoverable Error: 0 — Ignore 1 — Disables interrupt generation because of Unrecoverable Error. |
| 3 | RD | Resume Detect: 0 — Ignore 1 — Disables interrupt generation because of Resume Detect. |
| 2 | SF | Start-of-Frame: 0 — Ignore 1 — Disables interrupt generation because of Start-of-Frame. |
| 1 | WDH | HcDoneHead Writeback: 0 — Ignore 1 — Disables interrupt generation because of HcDoneHead Writeback. |
| 0 | SO | Scheduling Overrun: 0 — Ignore 1 — Disables interrupt generation because of Scheduling Overrun. |

11.1.7 HcHCCA register

The HcHCCA register contains the physical address of the Host Controller Communication Area (HCCA). The bit allocation is given in [Table 54](#). The HCD determines the alignment restrictions by writing all 1s to HcHCCA and reading the content of HcHCCA. The alignment is evaluated by examining the number of zeroes in the lower order bits. The minimum alignment is 256 B; therefore, bits 0 through 7 will always return logic 0 when read. This area is used to hold the control structures and the interrupt table that are accessed by both the Host Controller and the HCD.

Table 54: HcHCCA - Host Controller Communication Area register bit allocation

Address: Value read from func0 or func1 of address 10h + 18h

| Bit | 31 | 30 | 29 | 28 | 27 | 26 | 25 | 24 |
|--------|-------------------------|-----|-----|-----|-----|-----|-----|-----|
| Symbol | HCCA[23:16] | | | | | | | |
| Reset | 0 | 0 | 0 | 0 | 0 | 0 | 0 | 0 |
| Access | R/W | R/W | R/W | R/W | R/W | R/W | R/W | R/W |
| Bit | 23 | 22 | 21 | 20 | 19 | 18 | 17 | 16 |
| Symbol | HCCA[15:8] | | | | | | | |
| Reset | 0 | 0 | 0 | 0 | 0 | 0 | 0 | 0 |
| Access | R/W | R/W | R/W | R/W | R/W | R/W | R/W | R/W |
| Bit | 15 | 14 | 13 | 12 | 11 | 10 | 9 | 8 |
| Symbol | HCCA[7:0] | | | | | | | |
| Reset | 0 | 0 | 0 | 0 | 0 | 0 | 0 | 0 |
| Access | R/W | R/W | R/W | R/W | R/W | R/W | R/W | R/W |
| Bit | 7 | 6 | 5 | 4 | 3 | 2 | 1 | 0 |
| Symbol | reserved ^[1] | | | | | | | |
| Reset | 0 | 0 | 0 | 0 | 0 | 0 | 0 | 0 |
| Access | R/W | R/W | R/W | R/W | R/W | R/W | R/W | R/W |

[1] The reserved bits should always be written with the reset value.

Table 55: HcHCCA - Host Controller Communication Area register bit description

Address: Value read from func0 or func1 of address 10h + 18h

| Bit | Symbol | Description |
|---------|------------|---|
| 31 to 8 | HCCA[23:0] | Host Controller Communication Area Base Address: This is the base address of the HCCA. |
| 7 to 0 | reserved | - |

11.1.8 HcPeriodCurrentED register

The HcPeriodCurrentED register contains the physical address of the current isochronous or interrupt ED. [Table 56](#) shows the bit allocation of the register.

Table 56: HcPeriodCurrentED - Host Controller Period Current Endpoint Descriptor register bit allocation

Address: Value read from func0 or func1 of address 10h + 1Ch

| Bit | 31 | 30 | 29 | 28 | 27 | 26 | 25 | 24 |
|--------|-------------|----|----|----|----|----|----|----|
| Symbol | PCED[27:20] | | | | | | | |
| Reset | 0 | 0 | 0 | 0 | 0 | 0 | 0 | 0 |
| Access | R | R | R | R | R | R | R | R |

| | | | | | | | | |
|---------------|-------------|-----------|-----------|-----------|-----------|-----------|-----------|-----------|
| Bit | 23 | 22 | 21 | 20 | 19 | 18 | 17 | 16 |
| Symbol | PCED[19:12] | | | | | | | |
| Reset | 0 | 0 | 0 | 0 | 0 | 0 | 0 | 0 |
| Access | R | R | R | R | R | R | R | R |
| Bit | 15 | 14 | 13 | 12 | 11 | 10 | 9 | 8 |
| Symbol | PCED[11:4] | | | | | | | |
| Reset | 0 | 0 | 0 | 0 | 0 | 0 | 0 | 0 |
| Access | R | R | R | R | R | R | R | R |
| Bit | 7 | 6 | 5 | 4 | 3 | 2 | 1 | 0 |
| Symbol | PCED[3:0] | | | | reserved | | | |
| Reset | 0 | 0 | 0 | 0 | 0 | 0 | 0 | 0 |
| Access | R | R | R | R | R | R | R | R |

Table 57: HcPeriodCurrentED - Host Controller Period Current Endpoint Descriptor register bit description

Address: Value read from func0 or func1 of address 10h + 1Ch

| Bit | Symbol | Description |
|---------|------------|---|
| 31 to 4 | PCED[27:0] | PeriodCurrentED: This is used by the Host Controller to point to the head of one of the periodic lists that must be processed in the current frame. The content of this register is updated by the Host Controller after a periodic ED is processed. The HCD may read the content in determining which ED is being processed at the time of reading. |
| 3 to 0 | reserved | - |

11.1.9 HcControlHeadED register

The HcControlHeadED register contains the physical address of the first ED of the control list. The bit allocation is given in [Table 58](#).

Table 58: HcControlHeadED - Host Controller Control Head Endpoint Descriptor register bit allocation

Address: Value read from func0 or func1 of address 10h + 20h

| | | | | | | | | |
|---------------|-------------|-----------|-----------|-----------|-----------|-----------|-----------|-----------|
| Bit | 31 | 30 | 29 | 28 | 27 | 26 | 25 | 24 |
| Symbol | CHED[27:20] | | | | | | | |
| Reset | 0 | 0 | 0 | 0 | 0 | 0 | 0 | 0 |
| Access | R | R | R | R | R | R | R | R |
| Bit | 23 | 22 | 21 | 20 | 19 | 18 | 17 | 16 |
| Symbol | CHED[19:12] | | | | | | | |
| Reset | 0 | 0 | 0 | 0 | 0 | 0 | 0 | 0 |
| Access | R | R | R | R | R | R | R | R |
| Bit | 15 | 14 | 13 | 12 | 11 | 10 | 9 | 8 |
| Symbol | CHED[11:4] | | | | | | | |
| Reset | 0 | 0 | 0 | 0 | 0 | 0 | 0 | 0 |
| Access | R | R | R | R | R | R | R | R |
| Bit | 7 | 6 | 5 | 4 | 3 | 2 | 1 | 0 |
| Symbol | CHED[3:0] | | | | reserved | | | |
| Reset | 0 | 0 | 0 | 0 | 0 | 0 | 0 | 0 |
| Access | R | R | R | R | R | R | R | R |

Table 59: HcControlHeadED - Host Controller Control Head Endpoint Descriptor register bit description

Address: Value read from func0 or func1 of address 10h + 20h

| Bit | Symbol | Description |
|---------|------------|--|
| 31 to 4 | CHED[27:0] | ControlHeadED: The Host Controller traverses the control list, starting with the HcControlHeadED pointer. The content is loaded from HCCA during the initialization of the Host Controller. |
| 3 to 0 | reserved | - |

11.1.10 HcControlCurrentED register

The HcControlCurrentED register contains the physical address of the current ED of the control list. The bit allocation is given in [Table 60](#).

Table 60: HcControlCurrentED - Host Controller Control Current Endpoint Descriptor register bit allocation

Address: Value read from func0 or func1 of address 10h + 24h

| Bit | 31 | 30 | 29 | 28 | 27 | 26 | 25 | 24 |
|--------|-------------|----|----|----|----------|----|----|----|
| Symbol | CCED[27:20] | | | | | | | |
| Reset | 0 | 0 | 0 | 0 | 0 | 0 | 0 | 0 |
| Access | R | R | R | R | R | R | R | R |
| Bit | 23 | 22 | 21 | 20 | 19 | 18 | 17 | 16 |
| Symbol | CCED[19:12] | | | | | | | |
| Reset | 0 | 0 | 0 | 0 | 0 | 0 | 0 | 0 |
| Access | R | R | R | R | R | R | R | R |
| Bit | 15 | 14 | 13 | 12 | 11 | 10 | 9 | 8 |
| Symbol | CCED[11:4] | | | | | | | |
| Reset | 0 | 0 | 0 | 0 | 0 | 0 | 0 | 0 |
| Access | R | R | R | R | R | R | R | R |
| Bit | 7 | 6 | 5 | 4 | 3 | 2 | 1 | 0 |
| Symbol | CCED[3:0] | | | | reserved | | | |
| Reset | 0 | 0 | 0 | 0 | 0 | 0 | 0 | 0 |
| Access | R | R | R | R | R | R | R | R |

Table 61: HcControlCurrentED - Host Controller Control Current Endpoint Descriptor register bit description

Address: Value read from func0 or func1 of address 10h + 24h

| Bit | Symbol | Description |
|---------|------------|--|
| 31 to 4 | CCED[27:0] | ControlCurrentED: This pointer is advanced to the next ED after serving the present. The Host Controller must continue processing the list from where it left off in the last frame. When it reaches the end of the control list, the Host Controller checks CLF (bit 1 of HcCommandStatus). If set, it copies the content of HcControlHeadED to HcControlCurrentED and clears the bit. If not set, it does nothing. The HCD is allowed to modify this register only when CLE (bit 4 in the HcControl register) is cleared. When set, the HCD only reads the instantaneous value of this register. Initially, this is set to logic 0 to indicate the end of the control list. |
| 3 to 0 | reserved | - |

11.1.11 HcBulkHeadED register

This register (see [Table 62](#)) contains the physical address of the first ED of the bulk list.

Table 62: HcBulkHeadED - Host Controller Bulk Head Endpoint Descriptor register bit allocation

Address: Value read from func0 or func1 of address 10h + 28h

| Bit | 31 | 30 | 29 | 28 | 27 | 26 | 25 | 24 |
|--------|-------------|-----|-----|-----|-------------------------|-----|-----|-----|
| Symbol | BHED[27:20] | | | | | | | |
| Reset | 0 | 0 | 0 | 0 | 0 | 0 | 0 | 0 |
| Access | R/W | R/W | R/W | R/W | R/W | R/W | R/W | R/W |
| Bit | 23 | 22 | 21 | 20 | 19 | 18 | 17 | 16 |
| Symbol | BHED[19:12] | | | | | | | |
| Reset | 0 | 0 | 0 | 0 | 0 | 0 | 0 | 0 |
| Access | R/W | R/W | R/W | R/W | R/W | R/W | R/W | R/W |
| Bit | 15 | 14 | 13 | 12 | 11 | 10 | 9 | 8 |
| Symbol | BHED[11:4] | | | | | | | |
| Reset | 0 | 0 | 0 | 0 | 0 | 0 | 0 | 0 |
| Access | R/W | R/W | R/W | R/W | R/W | R/W | R/W | R/W |
| Bit | 7 | 6 | 5 | 4 | 3 | 2 | 1 | 0 |
| Symbol | BHED[3:0] | | | | reserved ^[1] | | | |
| Reset | 0 | 0 | 0 | 0 | 0 | 0 | 0 | 0 |
| Access | R/W | R/W | R/W | R/W | R/W | R/W | R/W | R/W |

[1] The reserved bits should always be written with the reset value.

Table 63: HcBulkHeadED - Host Controller Bulk Head Endpoint Descriptor register bit description

Address: Value read from func0 or func1 of address 10h + 28h

| Bit | Symbol | Description |
|---------|------------|--|
| 31 to 4 | BHED[27:0] | BulkHeadED: The Host Controller traverses the bulk list starting with the HcBulkHeadED pointer. The content is loaded from HCCA during the initialization of the Host Controller. |
| 3 to 0 | reserved | - |

11.1.12 HcBulkCurrentED register

This register contains the physical address of the current endpoint of the bulk list. The endpoints are ordered according to their insertion to the list because the bulk list must be served in a round-robin fashion. The bit allocation is given in [Table 64](#).

Table 64: HcBulkCurrentED - Host Controller Bulk Current Endpoint Descriptor register bit allocation

Address: Value read from func0 or func1 of address 10h + 2Ch

| Bit | 31 | 30 | 29 | 28 | 27 | 26 | 25 | 24 |
|--------|-------------|-----|-----|-----|-----|-----|-----|-----|
| Symbol | BCED[27:20] | | | | | | | |
| Reset | 0 | 0 | 0 | 0 | 0 | 0 | 0 | 0 |
| Access | R/W | R/W | R/W | R/W | R/W | R/W | R/W | R/W |

| | | | | | | | | |
|---------------|-------------|-----------|-----------|-----------|-------------------------|-----------|-----------|-----------|
| Bit | 23 | 22 | 21 | 20 | 19 | 18 | 17 | 16 |
| Symbol | BCED[19:12] | | | | | | | |
| Reset | 0 | 0 | 0 | 0 | 0 | 0 | 0 | 0 |
| Access | R/W | R/W | R/W | R/W | R/W | R/W | R/W | R/W |
| Bit | 15 | 14 | 13 | 12 | 11 | 10 | 9 | 8 |
| Symbol | BCED[11:4] | | | | | | | |
| Reset | 0 | 0 | 0 | 0 | 0 | 0 | 0 | 0 |
| Access | R/W | R/W | R/W | R/W | R/W | R/W | R/W | R/W |
| Bit | 7 | 6 | 5 | 4 | 3 | 2 | 1 | 0 |
| Symbol | BCED[3:0] | | | | reserved ^[1] | | | |
| Reset | 0 | 0 | 0 | 0 | 0 | 0 | 0 | 0 |
| Access | R/W | R/W | R/W | R/W | R/W | R/W | R/W | R/W |

[1] The reserved bits should always be written with the reset value.

Table 65: HcBulkCurrentED - Host Controller Bulk Current Endpoint Descriptor register bit description

Address: Value read from func0 or func1 of address 10h + 2Ch

| Bit | Symbol | Description |
|---------|------------|--|
| 31 to 4 | BCED[27:0] | BulkCurrentED: This is advanced to the next ED after the Host Controller has served the current ED. The Host Controller continues processing the list from where it left off in the last frame. When it reaches the end of the bulk list, the Host Controller checks CLF (bit 1 of HcCommandStatus). If the CLF bit is not set, nothing is done. If the CLF bit is set, it copies the content of HcBulkHeadED to HcBulkCurrentED and clears the CLF bit. The HCD can modify this register only when BLE (bit 5 in the HcControl register) is cleared. When HcControl is set, the HCD reads the instantaneous value of this register. This is initially set to logic 0 to indicate the end of the bulk list. |
| 3 to 0 | reserved | - |

11.1.13 HcDoneHead register

The HcDoneHead register contains the physical address of the last completed TD that was added to the Done queue. In normal operation, the HCD need not read this register because its content is periodically written to the HCCA. [Table 66](#) contains the bit allocation of the register.

Table 66: HcDoneHead - Host Controller Done Head register bit allocation

Address: Value read from func0 or func1 of address 10h + 30h

| | | | | | | | | |
|---------------|-----------|-----------|-----------|-----------|-----------|-----------|-----------|-----------|
| Bit | 31 | 30 | 29 | 28 | 27 | 26 | 25 | 24 |
| Symbol | DH[27:20] | | | | | | | |
| Reset | 0 | 0 | 0 | 0 | 0 | 0 | 0 | 0 |
| Access | R/W | R/W | R/W | R/W | R/W | R/W | R/W | R/W |
| Bit | 23 | 22 | 21 | 20 | 19 | 18 | 17 | 16 |
| Symbol | DH[19:12] | | | | | | | |
| Reset | 0 | 0 | 0 | 0 | 0 | 0 | 0 | 0 |
| Access | R/W | R/W | R/W | R/W | R/W | R/W | R/W | R/W |

| | | | | | | | | |
|---------------|-----------|-----------|-----------|-----------|--------------|-----------|----------|----------|
| Bit | 15 | 14 | 13 | 12 | 11 | 10 | 9 | 8 |
| Symbol | DH[11:4] | | | | | | | |
| Reset | 0 | 0 | 0 | 0 | 0 | 0 | 0 | 0 |
| Access | R/W | R/W | R/W | R/W | R/W | R/W | R/W | R/W |
| Bit | 7 | 6 | 5 | 4 | 3 | 2 | 1 | 0 |
| Symbol | DH[3:0] | | | | reserved [1] | | | |
| Reset | 0 | 0 | 0 | 0 | 0 | 0 | 0 | 0 |
| Access | R/W | R/W | R/W | R/W | R/W | R/W | R/W | R/W |

[1] The reserved bits should always be written with the reset value.

Table 67: HcDoneHead - Host Controller Done Head register bit description

Address: Value read from func0 or func1 of address 10h + 30h

| Bit | Symbol | Description |
|---------|----------|--|
| 31 to 4 | DH[27:0] | DoneHead: When a TD is completed, the Host Controller writes the content of HcDoneHead to the NextTD field of the TD. The Host Controller then overwrites the content of HcDoneHead with the address of this TD. This is set to logic 0 whenever the Host Controller writes the content of this register to HCCA. |
| 3 to 0 | reserved | - |

11.1.14 HcFmInterval register

This register contains a 14-bit value that indicates the bit time interval in a frame—that is, between two consecutive SOFs—and a 15-bit value indicating the full-speed maximum packet size that the Host Controller may transmit or receive, without causing a scheduling overrun. The HCD may carry out minor adjustment on FI (FrameInterval) by writing a new value over the present at each SOF. This provides the possibility for the Host Controller to synchronize with an external clocking resource and to adjust any unknown local clock offset. The bit allocation of the register is given in [Table 68](#).

Table 68: HcFmInterval - Host Controller Frame Interval register bit allocation

Address: Value read from func0 or func1 of address 10h + 34h

| | | | | | | | | |
|---------------|--------------|-------------|-----------|-----------|-----------|-----------|-----------|-----------|
| Bit | 31 | 30 | 29 | 28 | 27 | 26 | 25 | 24 |
| Symbol | FIT | FSMPS[14:8] | | | | | | |
| Reset | 0 | 0 | 0 | 0 | 0 | 0 | 0 | 0 |
| Access | R/W | R/W | R/W | R/W | R/W | R/W | R/W | R/W |
| Bit | 23 | 22 | 21 | 20 | 19 | 18 | 17 | 16 |
| Symbol | FSMPS[7:0] | | | | | | | |
| Reset | 0 | 0 | 0 | 0 | 0 | 0 | 0 | 0 |
| Access | R/W | R/W | R/W | R/W | R/W | R/W | R/W | R/W |
| Bit | 15 | 14 | 13 | 12 | 11 | 10 | 9 | 8 |
| Symbol | reserved [1] | | FI[13:8] | | | | | |
| Reset | 0 | 0 | 1 | 0 | 1 | 1 | 1 | 0 |
| Access | R/W | R/W | R/W | R/W | R/W | R/W | R/W | R/W |

| Bit | 7 | 6 | 5 | 4 | 3 | 2 | 1 | 0 |
|--------|---------|-----|-----|-----|-----|-----|-----|-----|
| Symbol | FI[7:0] | | | | | | | |
| Reset | 1 | 1 | 0 | 1 | 1 | 1 | 1 | 1 |
| Access | R/W | R/W | R/W | R/W | R/W | R/W | R/W | R/W |

[1] The reserved bits should always be written with the reset value.

Table 69: HcFmInterval - Host Controller Frame Interval register bit description

Address: Value read from func0 or func1 of address 10h + 34h

| Bit | Symbol | Description |
|----------|-------------|---|
| 31 | FIT | FrameIntervalToggle: The HCD toggles this bit whenever it loads a new value to FrameInterval. |
| 30 to 16 | FSMPS[14:0] | FSLargestDataPacket: This field specifies the value that is loaded into the largest data packet counter at the beginning of each frame. The counter value represents the largest amount of data in bits that can be sent or received by the Host Controller in a single transaction at any given time, without causing a scheduling overrun. The field value is calculated by the HCD. |
| 15 to 14 | reserved | - |
| 13 to 0 | FI[13:0] | FrameInterval: This specifies the interval between two consecutive SOFs in bit times. The nominal value is set to 11,999. The HCD should store the current value of this field before resetting the Host Controller to reset this field to its nominal value. The HCD can then restore the stored value on completing the reset sequence. |

11.1.15 HcFmRemaining register

This register is a 14-bit down counter showing the bit time remaining in the current frame.

[Table 70](#) contains the bit allocation of this register.

Table 70: HcFmRemaining - Host Controller Frame Remaining register bit allocation

Address: Value read from func0 or func1 of address 10h + 38h

| | | | | | | | | |
|---------------|-------------------------|-------------------------|-----------|-----------|-----------|-----------|-----------|-----------|
| Bit | 31 | 30 | 29 | 28 | 27 | 26 | 25 | 24 |
| Symbol | FRT | reserved ^[1] | | | | | | |
| Reset | 0 | 0 | 0 | 0 | 0 | 0 | 0 | 0 |
| Access | R/W | R/W | R/W | R/W | R/W | R/W | R/W | R/W |
| Bit | 23 | 22 | 21 | 20 | 19 | 18 | 17 | 16 |
| Symbol | reserved ^[1] | | | | | | | |
| Reset | 0 | 0 | 0 | 0 | 0 | 0 | 0 | 0 |
| Access | R/W | R/W | R/W | R/W | R/W | R/W | R/W | R/W |
| Bit | 15 | 14 | 13 | 12 | 11 | 10 | 9 | 8 |
| Symbol | reserved ^[1] | | FR[13:8] | | | | | |
| Reset | 0 | 0 | 0 | 0 | 0 | 0 | 0 | 0 |
| Access | R/W | R/W | R/W | R/W | R/W | R/W | R/W | R/W |
| Bit | 7 | 6 | 5 | 4 | 3 | 2 | 1 | 0 |
| Symbol | FR[7:0] | | | | | | | |
| Reset | 0 | 0 | 0 | 0 | 0 | 0 | 0 | 0 |
| Access | R/W | R/W | R/W | R/W | R/W | R/W | R/W | R/W |

[1] The reserved bits should always be written with the reset value.

Table 71: HcFmRemaining - Host Controller Frame Remaining register bit description

Address: Value read from func0 or func1 of address 10h + 38h

| Bit | Symbol | Description |
|----------|----------|--|
| 31 | FRT | FrameRemainingToggle: This bit is loaded from FIT (bit 31 of HcFmInterval) whenever FR[13:0] reaches 0. This bit is used by the HCD for the synchronization between FI[13:0] (bits 13 to 0 of HcFmInterval) and FR[13:0]. |
| 30 to 14 | reserved | - |
| 13 to 0 | FR[13:0] | FrameRemaining: This counter is decremented at each bit time. When it reaches 0, it is reset by loading the FI[13:0] value specified in HcFmInterval at the next bit time boundary. When entering the USBOPERATIONAL state, the Host Controller reloads the content with FI[13:0] of HcFmInterval and uses the updated value from the next SOF. |

11.1.16 HcFmNumber register

This register is a 16-bit counter, and the bit allocation is given in [Table 72](#). It provides a timing reference among events happening in the Host Controller and the HCD. The HCD may use the 16-bit value specified in this register and generate a 32-bit frame number, without requiring frequent access to the register.

Table 72: HcFmNumber - Host Controller Frame Number register bit allocation

Address: Value read from func0 or func1 of address 10h + 3Ch

| | | | | | | | | |
|---------------|-------------------------|-----------|-----------|-----------|-----------|-----------|-----------|-----------|
| Bit | 31 | 30 | 29 | 28 | 27 | 26 | 25 | 24 |
| Symbol | reserved ^[1] | | | | | | | |
| Reset | 0 | 0 | 0 | 0 | 0 | 0 | 0 | 0 |
| Access | R/W | R/W | R/W | R/W | R/W | R/W | R/W | R/W |

| | | | | | | | | |
|---------------|--------------|-----------|-----------|-----------|-----------|-----------|-----------|-----------|
| Bit | 23 | 22 | 21 | 20 | 19 | 18 | 17 | 16 |
| Symbol | reserved [1] | | | | | | | |
| Reset | 0 | 0 | 0 | 0 | 0 | 0 | 0 | 0 |
| Access | R/W | R/W | R/W | R/W | R/W | R/W | R/W | R/W |
| Bit | 15 | 14 | 13 | 12 | 11 | 10 | 9 | 8 |
| Symbol | reserved [1] | | FN[13:8] | | | | | |
| Reset | 0 | 0 | 0 | 0 | 0 | 0 | 0 | 0 |
| Access | R/W | R/W | R/W | R/W | R/W | R/W | R/W | R/W |
| Bit | 7 | 6 | 5 | 4 | 3 | 2 | 1 | 0 |
| Symbol | FN[7:0] | | | | | | | |
| Reset | 0 | 0 | 0 | 0 | 0 | 0 | 0 | 0 |
| Access | R/W | R/W | R/W | R/W | R/W | R/W | R/W | R/W |

[1] The reserved bits should always be written with the reset value.

Table 73: HcFmNumber - Host Controller Frame Number register bit description

Address: Value read from func0 or func1 of address 10h + 3Ch

| Bit | Symbol | Description |
|----------|----------|---|
| 31 to 14 | reserved | - |
| 13 to 0 | FN[13:0] | FrameNumber: Incremented when HcFmRemaining is reloaded. It must be rolled over to 0h after FFFFh. Automatically incremented when entering the USBOPERATIONAL state. The content is written to HCCA after the Host Controller has incremented FrameNumber at each frame boundary and sent an SOF but before the Host Controller reads the first ED in that frame. After writing to HCCA, the Host Controller sets SF (bit 2 in HcInterruptStatus). |

11.1.17 HcPeriodicStart register

This register has a 14-bit programmable value that determines when is the earliest time for the Host Controller to start processing the periodic list. For bit allocation, see [Table 74](#).

Table 74: HcPeriodicStart - Host Controller Periodic Start register bit allocation

Address: Value read from func0 or func1 of address 10h + 40h

| | | | | | | | | |
|---------------|--------------|-----------|-----------|-----------|-----------|-----------|-----------|-----------|
| Bit | 31 | 30 | 29 | 28 | 27 | 26 | 25 | 24 |
| Symbol | reserved [1] | | | | | | | |
| Reset | 0 | 0 | 0 | 0 | 0 | 0 | 0 | 0 |
| Access | R/W | R/W | R/W | R/W | R/W | R/W | R/W | R/W |
| Bit | 23 | 22 | 21 | 20 | 19 | 18 | 17 | 16 |
| Symbol | reserved [1] | | | | | | | |
| Reset | 0 | 0 | 0 | 0 | 0 | 0 | 0 | 0 |
| Access | R/W | R/W | R/W | R/W | R/W | R/W | R/W | R/W |
| Bit | 15 | 14 | 13 | 12 | 11 | 10 | 9 | 8 |
| Symbol | reserved [1] | | P_S[13:8] | | | | | |
| Reset | 0 | 0 | 0 | 0 | 0 | 0 | 0 | 0 |
| Access | R/W | R/W | R/W | R/W | R/W | R/W | R/W | R/W |

| Bit | 7 | 6 | 5 | 4 | 3 | 2 | 1 | 0 |
|--------|----------|-----|-----|-----|-----|-----|-----|-----|
| Symbol | P_S[7:0] | | | | | | | |
| Reset | 0 | 0 | 0 | 0 | 0 | 0 | 0 | 0 |
| Access | R/W | R/W | R/W | R/W | R/W | R/W | R/W | R/W |

[1] The reserved bits should always be written with the reset value.

Table 75: HcPeriodicStart - Host Controller Periodic Start register bit description

Address: Value read from func0 or func1 of address 10h + 40h

| Bit | Symbol | Description |
|----------|-----------|---|
| 31 to 14 | reserved | - |
| 13 to 0 | P_S[13:0] | PeriodicStart: After a hardware reset, this field is cleared. It is then set by the HCD during the Host Controller initialization. The value is roughly calculated as 10 % of HcFmInterval. A typical value is 3E67h. When HcFmRemaining reaches the value specified, processing of the periodic lists have priority over control or bulk processing. The Host Controller, therefore, starts processing the interrupt list after completing the current control or bulk transaction that is in progress. |

11.1.18 HcLSThreshold register

This register contains an 11-bit value used by the Host Controller to determine whether to commit to the transfer of a maximum of 8 B low-speed packet before EOF. Neither the Host Controller nor the HCD can change this value. For bit allocation, see [Table 76](#).

Table 76: HcLSThreshold - Host Controller LS Threshold register bit allocation

Address: Value read from func0 or func1 of address 10h + 44h

| Bit | 31 | 30 | 29 | 28 | 27 | 26 | 25 | 24 |
|--------|--------------|-----|-----|-----|-----------|-----|-----|-----|
| Symbol | reserved [1] | | | | | | | |
| Reset | 0 | 0 | 0 | 0 | 0 | 0 | 0 | 0 |
| Access | R/W | R/W | R/W | R/W | R/W | R/W | R/W | R/W |
| Bit | 23 | 22 | 21 | 20 | 19 | 18 | 17 | 16 |
| Symbol | reserved [1] | | | | | | | |
| Reset | 0 | 0 | 0 | 0 | 0 | 0 | 0 | 0 |
| Access | R/W | R/W | R/W | R/W | R/W | R/W | R/W | R/W |
| Bit | 15 | 14 | 13 | 12 | 11 | 10 | 9 | 8 |
| Symbol | reserved [1] | | | | LST[11:8] | | | |
| Reset | 0 | 0 | 0 | 0 | 0 | 1 | 1 | 0 |
| Access | R/W | R/W | R/W | R/W | R/W | R/W | R/W | R/W |
| Bit | 7 | 6 | 5 | 4 | 3 | 2 | 1 | 0 |
| Symbol | LST[7:0] | | | | | | | |
| Reset | 0 | 0 | 1 | 0 | 1 | 0 | 0 | 0 |
| Access | R/W | R/W | R/W | R/W | R/W | R/W | R/W | R/W |

[1] The reserved bits should always be written with the reset value.

Table 77: HcLSThreshold - Host Controller LS Threshold register bit description

Address: Value read from func0 or func1 of address 10h + 44h

| Bit | Symbol | Description |
|----------|-----------|--|
| 31 to 12 | reserved | - |
| 11 to 0 | LST[11:0] | LSThreshold: This field contains a value that is compared to the FR[13:0] field, before initiating a low-speed transaction. The transaction is started only if $FR \geq$ this field. The value is calculated by the HCD, considering the transmission and setup overhead. |

11.1.19 HcRhDescriptorA register

This register is the first of two registers describing the characteristics of the Root Hub. Reset values are implementation-specific.

[Table 78](#) contains the bit allocation of the HcRhDescriptorA register.

Table 78: HcRhDescriptorA - Host Controller Root Hub Descriptor A register bit allocation

Address: Value read from func0 or func1 of address 10h + 48h

| Bit | 31 | 30 | 29 | 28 | 27 | 26 | 25 | 24 |
|--------|--------------|-----|-----|------|------|-----|-----|-----|
| Symbol | POTPGT[7:0] | | | | | | | |
| Reset | 1 | 1 | 1 | 1 | 1 | 1 | 1 | 1 |
| Access | R/W | R/W | R/W | R/W | R/W | R/W | R/W | R/W |
| Bit | 23 | 22 | 21 | 20 | 19 | 18 | 17 | 16 |
| Symbol | reserved [1] | | | | | | | |
| Reset | 0 | 0 | 0 | 0 | 0 | 0 | 0 | 0 |
| Access | R/W | R/W | R/W | R/W | R/W | R/W | R/W | R/W |
| Bit | 15 | 14 | 13 | 12 | 11 | 10 | 9 | 8 |
| Symbol | reserved [1] | | | NOCP | OCPM | DT | NPS | PSM |
| Reset | 0 | 0 | 0 | 0 | 1 | 0 | 0 | 1 |
| Access | R/W | R/W | R/W | R/W | R/W | R | R/W | R/W |
| Bit | 7 | 6 | 5 | 4 | 3 | 2 | 1 | 0 |
| Symbol | NDP[7:0] | | | | | | | |
| Reset | 0 | 0 | 0 | 0 | 0 | 0 | 0 | 1 |
| Access | R | R | R | R | R | R | R | R |

[1] The reserved bits should always be written with the reset value.

Table 79: HcRhDescriptorA - Host Controller Root Hub Descriptor A register bit description

Address: Value read from func0 or func1 of address 10h + 48h

| Bit | Symbol | Description |
|----------|--------------|--|
| 31 to 24 | POTPGT [7:0] | PowerOnToPowerGoodTime: This byte specifies the duration the HCD must wait before accessing a powered-on port of the Root Hub. It is implementation-specific. The unit of time is 2 ms. The duration is calculated as POTPGT x 2 ms. |
| 23 to 13 | reserved | - |
| 12 | NOCP | NoOverCurrentProtection: This bit describes how the overcurrent status for Root Hub ports are reported. When this bit is cleared, the OCPM bit specifies global or per-port reporting. 0 — Overcurrent status is collectively reported for all downstream ports 1 — No overcurrent protection supported. |
| 11 | OCPM | OverCurrentProtectionMode: This bit describes how the overcurrent status for Root Hub ports are reported. At reset, this fields reflects the same mode as PowerSwitchingMode. This field is valid only if the NOCP bit is cleared. 0 — Overcurrent status is collectively reported for all downstream ports 1 — Overcurrent status is reported on a per-port basis. |
| 10 | DT | DeviceType: This bit specifies that the Root Hub is not a compound device. The Root Hub is not permitted to be a compound device. This field should always read logic 0. |
| 9 | NPS | NoPowerSwitching: This bit is used to specify whether power switching is supported or ports are always powered. It is implementation-specific. When this bit is cleared, the PSM bit specifies global or per-port switching. 0 — Ports are power switched 1 — Ports are always powered on when the Host Controller is powered on. |
| 8 | PSM | PowerSwitchingMode: This bit is used to specify how the power switching of Root Hub ports is controlled. It is implementation-specific. This field is only valid if the NPS field is cleared. 0 — All ports are powered at the same time 1 — Each port is individually powered. This mode allows port power to be controlled by either the global switch or per-port switching. If the PPCM (PortPowerControlMask) bit is set, the port responds only to port power commands (Set/ClearPortPower). If the port mask is cleared, then the port is controlled only by the global power switch (Set/ClearGlobalPower). |
| 7 to 0 | NDP[7:0] | NumberDownstreamPorts: These bits specify the number of downstream ports supported by the Root Hub. It is implementation-specific. The minimum number of ports is 1. The maximum number of ports supported by OHCI is 15. |

11.1.20 HcRhDescriptorB register

The HcRhDescriptorB register is the second of two registers describing the characteristics of the Root Hub. The bit allocation is given in [Table 80](#). These fields are written during initialization to correspond to the system implementation. Reset values are implementation-specific.

Table 80: HcRhDescriptorB - Host Controller Root Hub Descriptor B register bit allocation

Address: Value read from func0 or func1 of address 10h + 4Ch

| | | | | | | | | |
|---------------|------------|-----------|-----------|-----------|-----------|-----------|-----------|-----------|
| Bit | 31 | 30 | 29 | 28 | 27 | 26 | 25 | 24 |
| Symbol | PPCM[15:0] | | | | | | | |
| Reset | 0 | 0 | 0 | 0 | 0 | 0 | 0 | 0 |
| Access | R/W | R/W | R/W | R/W | R | R/W | R/W | R/W |
| Bit | 23 | 22 | 21 | 20 | 19 | 18 | 17 | 16 |
| Symbol | PPCM[7:0] | | | | | | | |
| Reset | 0 | 0 | 0 | 0 | 0 | 0 | 1 | 0 |
| Access | R/W | R/W | R/W | R/W | R/W | R/W | R/W | R/W |
| Bit | 15 | 14 | 13 | 12 | 11 | 10 | 9 | 8 |
| Symbol | DR[15:8] | | | | | | | |
| Reset | 0 | 0 | 0 | 0 | 0 | 0 | 0 | 0 |
| Access | R/W | R/W | R/W | R/W | R/W | R/W | R/W | R/W |
| Bit | 7 | 6 | 5 | 4 | 3 | 2 | 1 | 0 |
| Symbol | DR[7:0] | | | | | | | |
| Reset | 0 | 0 | 0 | 0 | 0 | 0 | 0 | 0 |
| Access | R/W | R/W | R/W | R/W | R/W | R/W | R/W | R/W |

Table 81: HcRhDescriptorB - Host Controller Root Hub Descriptor B register bit description

Address: Value read from func0 or func1 of address 10h + 4Ch

| Bit | Symbol | Description |
|----------|-------------|---|
| 31 to 16 | PPCM [15:0] | PortPowerControlMask: Each bit indicates whether a port is affected by a global power control command when PowerSwitchingMode is set. When set, only the power state of the port is affected by per-port power control (Set/ClearPortPower). When cleared, the port is controlled by the global power switch (Set/ClearGlobalPower). If the device is configured to global switching mode (PowerSwitchingMode = 0), this field is not valid. Bit 0 — Reserved Bit 1 — Ganged-power mask on port 1 Bit 2 — Ganged-power mask on port 2. |
| 15 to 0 | DR [15:0] | DeviceRemovable: Each bit is dedicated to a port of the Root Hub. When cleared, the attached device is removable. When set, the attached device is not removable. Bit 0 — Reserved Bit 1 — Device attached to port 1 Bit 2 — Device attached to port 2. |

11.1.21 HcRhStatus register

This register is divided into two parts. The lower word of a DWord represents the Hub Status field, and the upper word represents the Hub Status Change field. Reserved bits should always be written as logic 0. [Table 82](#) shows the bit allocation of the register.

Table 82: HcRhStatus - Host Controller Root Hub Status register bit allocation

Address: Value read from func0 or func1 of address 10h + 50h

| | | | | | | | | |
|---------------|-------------------------|-------------------------|-----------|-----------|-----------|-----------|-----------|-----------|
| Bit | 31 | 30 | 29 | 28 | 27 | 26 | 25 | 24 |
| Symbol | CRWE | reserved ^[1] | | | | | | |
| Reset | 0 | 0 | 0 | 0 | 0 | 0 | 0 | 0 |
| Access | R/W | R/W | R/W | R/W | R/W | R/W | R/W | R/W |
| Bit | 23 | 22 | 21 | 20 | 19 | 18 | 17 | 16 |
| Symbol | reserved ^[1] | | | | | | CCIC | LPSC |
| Reset | 0 | 0 | 0 | 0 | 0 | 0 | 0 | 0 |
| Access | R/W | R/W | R/W | R/W | R/W | R/W | R/W | R/W |
| Bit | 15 | 14 | 13 | 12 | 11 | 10 | 9 | 8 |
| Symbol | DRWE | reserved ^[1] | | | | | | |
| Reset | 0 | 0 | 0 | 0 | 0 | 0 | 0 | 0 |
| Access | R/W | R/W | R/W | R/W | R/W | R/W | R/W | R/W |
| Bit | 7 | 6 | 5 | 4 | 3 | 2 | 1 | 0 |
| Symbol | reserved ^[1] | | | | | | OCI | LPS |
| Reset | 0 | 0 | 0 | 0 | 0 | 0 | 0 | 0 |
| Access | R/W | R/W | R/W | R/W | R/W | R/W | R | RW |

[1] The reserved bits should always be written with the reset value.

Table 83: HcRhStatus - Host Controller Root Hub Status register bit description

Address: Value read from func0 or func1 of address 10h + 50h

| Bit | Symbol | Description |
|----------|----------|---|
| 31 | CRWE | On write— ClearRemoteWakeupEnable : 0 — No effect 1 — Clears DRWE (DeviceRemoteWakeupEnable). |
| 30 to 18 | reserved | - |
| 17 | CCIC | OverCurrentIndicatorChange : This bit is set by hardware when a change has occurred to the OCI bit of this register. 0 — No effect 1 — The HCD clears this bit. |
| 16 | LPSC | On read— LocalPowerStatusChange : The Root Hub does not support the local power status feature. Therefore, this bit is always logic 0. On write— SetGlobalPower : In global power mode (PowerSwitchingMode = 0), logic 1 is written to this bit to turn on power to all ports (clear PortPowerStatus). In per-port power mode, it sets PortPowerStatus only on ports whose PortPowerControlMask bit is not set. Writing logic 0 has no effect. |
| 15 | DRWE | On read— DeviceRemoteWakeupEnable : This bit enables bit ConnectStatusChange (CSC) as a resume event, causing a state transition from USBsuspend to USBRESUME and setting the ResumeDetected interrupt. 0 — CSC is not a remote wake-up event 1 — CSC is a remote wake-up event. On write— SetRemoteWakeupEnable : Writing logic 1 sets DRWE (DeviceRemoteWakeupEnable). Writing logic 0 has no effect. |

Table 83: HcRhStatus - Host Controller Root Hub Status register bit description...continued
 Address: Value read from func0 or func1 of address 10h + 50h

| Bit | Symbol | Description |
|---------|----------|--|
| 14 to 2 | reserved | - |
| 1 | OCI | OverCurrentIndicator: This bit reports overcurrent conditions when global reporting is implemented. When set, an overcurrent condition exists. When cleared, all power operations are normal. If the per-port overcurrent protection is implemented, this bit is always logic 0. |
| 0 | LPS | On read— LocalPowerStatus: The Root Hub does not support the local power status feature. Therefore, this bit is always read as logic 0. On write— ClearGlobalPower: In global power mode (PowerSwitchingMode = 0), logic 1 is written to this bit to turn off power to all ports (clear PortPowerStatus). In per-port power mode, it clears PortPowerStatus only on ports whose PortPowerControlMask bit is not set. Writing logic 0 has no effect. |

11.1.22 HcRhPortStatus[4:1] register

The HcRhPortStatus[4:1] register is used to control and report port events on a per-port basis. NumberDownstreamPorts represents the number of HcRhPortStatus registers that are implemented in hardware. The lower word reflects the port status. The upper word reflects the status change bits. Some status bits are implemented with special write behavior. If a transaction—token through handshake—is in progress when a write to change port status occurs, the resulting port status change is postponed until the transaction completes. Always write logic 0 to the reserved bits. The bit allocation of the register is given in [Table 84](#).

Table 84: HcRhPortStatus[4:1] - Host Controller Root Hub Port Status[4:1] register bit allocation
 Address: Value read from func0 or func1 of address 10h + 54h

| Bit | 31 | 30 | 29 | 28 | 27 | 26 | 25 | 24 |
|--------|-------------------------|-----|-----|------|------|------|------|-----|
| Symbol | reserved ^[1] | | | | | | | |
| Reset | 0 | 0 | 0 | 0 | 0 | 0 | 0 | 0 |
| Access | R/W | R/W | R/W | R/W | R/W | R/W | R/W | R/W |
| Bit | 23 | 22 | 21 | 20 | 19 | 18 | 17 | 16 |
| Symbol | reserved ^[1] | | | PRSC | OCIC | PSSC | PESC | CSC |
| Reset | 0 | 0 | 0 | 0 | 0 | 0 | 0 | 0 |
| Access | R/W | R/W | R/W | R/W | R/W | R/W | R/W | R/W |
| Bit | 15 | 14 | 13 | 12 | 11 | 10 | 9 | 8 |
| Symbol | reserved ^[1] | | | | | | LSDA | PPS |
| Reset | 0 | 0 | 0 | 0 | 0 | 0 | 0 | 0 |
| Access | R/W | R/W | R/W | R/W | R/W | R/W | R/W | R/W |
| Bit | 7 | 6 | 5 | 4 | 3 | 2 | 1 | 0 |
| Symbol | reserved ^[1] | | | PRS | POCI | PSS | PES | CCS |
| Reset | 0 | 0 | 0 | 0 | 0 | 0 | 0 | 0 |
| Access | R/W | R/W | R/W | R/W | R/W | R/W | R/W | R/W |

[1] The reserved bits should always be written with the reset value.

Table 85: HcRhPortStatus[4:1] - Host Controller Root Hub Port Status[4:1] register bit description

Address: Value read from func0 or func1 of address 10h + 54h

| Bit | Symbol | Description |
|----------|----------|---|
| 31 to 21 | reserved | - |
| 20 | PRSC | <p>PortResetStatusChange: This bit is set at the end of the 10 ms port reset signal. The HCD can write logic 1 to clear this bit. Writing logic 0 has no effect.</p> <p>0 — Port reset is not complete 1 — Port reset is complete.</p> |
| 19 | OCIC | <p>PortOverCurrentIndicatorChange: This bit is valid only if overcurrent conditions are reported on a per-port basis. This bit is set when the Root Hub changes the POCI (PortOverCurrentIndicator) bit. The HCD can write logic 1 to clear this bit. Writing logic 0 has no effect.</p> <p>0 — No change in POCI 1 — POCI has changed.</p> |
| 18 | PSSC | <p>PortSuspendStatusChange: This bit is set when the resume sequence is completed. This sequence includes the 20 ms resume pulse, LS EOP and 3 ms resynchronization delay. The HCD can write logic 1 to clear this bit. Writing logic 0 has no effect. This bit is also cleared when ResetStatusChange is set.</p> <p>0 — Resume is not completed 1 — Resume is completed.</p> |
| 17 | PESC | <p>PortEnableStatusChange: This bit is set when hardware events cause the PES (PortEnableStatus) bit to be cleared. Changes from the HCD writes do not set this bit. The HCD can write logic 1 to clear this bit. Writing logic 0 has no effect.</p> <p>0 — No change in PES 1 — Change in PES.</p> |
| 16 | CSC | <p>ConnectStatusChange: This bit is set whenever a connect or disconnect event occurs. The HCD can write logic 1 to clear this bit. Writing logic 0 has no effect. If CCS (Current Connect Status) is cleared when a SetPortReset, SetPortEnable or SetPortSuspend write occurs, this bit is set to force the driver to re-evaluate the connection status because these writes should not occur if the port is disconnected.</p> <p>0 — No change in CCS 1 — Change in CCS.</p> <p>Remark: If the DeviceRemovable[NDP] bit is set, this bit is set only after a Root Hub reset to inform the system that the device is attached.</p> |
| 15 to 10 | reserved | - |
| 9 | LSDA | <p>On read—LowSpeedDeviceAttached: This bit indicates the speed of the device attached to this port. When set, a low-speed device is attached to this port. When cleared, a full-speed device is attached to this port. This field is valid only when CCS is set.</p> <p>0 — Port is not suspended 1 — Port is suspended.</p> <p>On write—ClearPortPower: The HCD can clear the PPS (PortPowerStatus) bit by writing logic 1 to this bit. Writing logic 0 has no effect.</p> |

Table 85: HcRhPortStatus[4:1] - Host Controller Root Hub Port Status[4:1] register bit description...continued

Address: Value read from func0 or func1 of address 10h + 54h

| Bit | Symbol | Description |
|--------|----------|--|
| 8 | PPS | <p>On read—PortPowerStatus: This bit reflects the port power status, regardless of the type of power switching implemented. This bit is cleared if an overcurrent condition is detected. The HCD can set this bit by writing SetPortPower or SetGlobalPower. The HCD can clear this bit by writing ClearPortPower or ClearGlobalPower. PowerSwitchingMode and PortPowerControlMask[NDP] determine which power control switches are enabled. In global switching mode (PowerSwitchingMode = 0), only Set/ClearGlobalPower controls this bit. In the per-port power switching (PowerSwitchingMode = 1), if the PortPowerControlMask[NDP] bit for the port is set, only Set/ClearPortPower commands are enabled. If the mask is not set, only Set/ClearGlobalPower commands are enabled.</p> <p>When port power is disabled, bits CCS (CurrentConnectStatus), PES (PortEnableStatus), PSS (PortSuspendStatus) and PRS (PortResetStatus) should be reset.</p> <p>0 — Port power is off 1 — Port power is on.</p> <p>On write—SetPortPower: The HCD can write logic 1 to set the PPS (PortPowerStatus) bit. Writing logic 0 has no effect.</p> <p>Remark: This bit always reads logic 1 if power switching is not supported.</p> |
| 7 to 5 | reserved | - |
| 4 | PRS | <p>On read—PortResetStatus: When this bit is set by a write to SetPortReset, port reset signaling is asserted. When reset is completed and PRSC is set, this bit is cleared.</p> <p>0 — Port reset signal is inactive 1 — Port reset signal is active.</p> <p>On write—SetPortReset: The HCD can set the port reset signaling by writing logic 1 to this bit. Writing logic 0 has no effect. If CCS is cleared, this write does not set PRS (PortResetStatus) but instead sets CCS. This informs the driver that it attempted to reset a disconnected port.</p> |
| 3 | POCI | <p>On read—PortOverCurrentIndicator: This bit is valid only when the Root Hub is configured to show overcurrent conditions are reported on a per-port basis. If the per-port overcurrent reporting is not supported, this bit is set to logic 0. If cleared, all power operations are normal for this port. If set, an overcurrent condition exists on this port.</p> <p>0 — No overcurrent condition 1 — Overcurrent condition detected.</p> <p>On write—ClearSuspendStatus: The HCD can write logic 1 to initiate a resume. Writing logic 0 has no effect. A resume is initiated only if PSS (PortSuspendStatus) is set.</p> |

Table 85: HcRhPortStatus[4:1] - Host Controller Root Hub Port Status[4:1] register bit description...continued

Address: Value read from func0 or func1 of address 10h + 54h

| Bit | Symbol | Description |
|-----|--------|---|
| 2 | PSS | <p>On read—PortSuspendStatus: This bit indicates whether the port is suspended or is in the resume sequence. It is set by a SetSuspendState write and cleared when PSSC (PortSuspendStatusChange) is set at the end of the resume interval. This bit is not set if CCS (CurrentConnectStatus) is cleared. This bit is also cleared when PRSC is set at the end of the port reset or when the Host Controller is placed in the USBRESUME state. If an upstream resume is in progress, it will propagate to the Host Controller.</p> <p>0 — Port is not suspended 1 — Port is suspended.</p> <p>On write—SetPortSuspend: The HCD can set the PSS (PortSuspendStatus) bit by writing logic 1 to this bit. Writing logic 0 has no effect. If CCS is cleared, this write does not set PSS; instead it sets CSS. This informs the driver that it attempted to suspend a disconnected port.</p> |
| 1 | PES | <p>On read—PortEnableStatus: This bit indicates whether the port is enabled or disabled. The Root Hub may clear this bit when an overcurrent condition, disconnect event, switched-off power or operational bus error is detected. This change also causes PortEnabledStatusChange to be set. The HCD can set this bit by writing SetPortEnable and clear it by writing ClearPortEnable. This bit cannot be set when CCS (CurrentConnectStatus) is cleared. This bit is also set on completing a port reset when ResetStatusChange is set or on completing a port suspend when SuspendStatusChange is set.</p> <p>0 — Port is disabled 1 — Port is enabled.</p> <p>On write—SetPortEnable: The HCD can set PES (PortEnableStatus) by writing logic 1. Writing logic 0 has no effect. If CCS is cleared, this write does not set PES, but instead sets CSC (ConnectStatusChange). This informs the driver that it attempted to enable a disconnected port.</p> |
| 0 | CCS | <p>On read—CurrentConnectStatus: This bit reflects the current state of the downstream port.</p> <p>0 — No device connected 1 — Device connected.</p> <p>On write—ClearPortEnable: The HCD can write logic 1 to this bit to clear the PES (PortEnableStatus) bit. Writing logic 0 has no effect. The CCS bit is not affected by any write.</p> <p>Remark: This bit always reads logic 1 when the attached device is nonremovable (DeviceRemovable[NDP]).</p> |

11.2 EHCI controller capability registers

Other than the OHCI Host Controller, there are some registers in EHCI that define the capability of EHCI. The address range of these registers is located before the operational registers.

11.2.1 CAPLENGTH/HCVERSION register

The bit allocation of this 4 B register is given in [Table 86](#).

Table 86: CAPLENGTH/HCVERSION - Capability Registers Length/Host Controller Interface Version Number register bit allocation

Address: Value read from func2 of address 10h + 00h

| | | | | | | | | |
|---------------|-----------------|-----------|-----------|-----------|-----------|-----------|-----------|-----------|
| Bit | 31 | 30 | 29 | 28 | 27 | 26 | 25 | 24 |
| Symbol | HCVERSION[15:8] | | | | | | | |
| Reset | 0 | 0 | 0 | 0 | 0 | 0 | 0 | 1 |
| Access | R | R | R | R | R | R | R | R |
| Bit | 23 | 22 | 21 | 20 | 19 | 18 | 17 | 16 |
| Symbol | HCVERSION[7:0] | | | | | | | |
| Reset | 0 | 0 | 0 | 0 | 0 | 0 | 0 | 0 |
| Access | R | R | R | R | R | R | R | R |
| Bit | 15 | 14 | 13 | 12 | 11 | 10 | 9 | 8 |
| Symbol | reserved | | | | | | | |
| Reset | 0 | 0 | 0 | 0 | 0 | 0 | 0 | 0 |
| Access | R | R | R | R | R | R | R | R |
| Bit | 7 | 6 | 5 | 4 | 3 | 2 | 1 | 0 |
| Symbol | CAPLENGTH[7:0] | | | | | | | |
| Reset | 0 | 0 | 1 | 0 | 0 | 0 | 0 | 0 |
| Access | R | R | R | R | R | R | R | R |

Table 87: CAPLENGTH/HCVERSION - Capability Registers Length/Host Controller Interface Version Number register bit description

Address: Value read from func2 of address 10h + 00h

| Bit | Symbol | Description |
|----------|------------------|---|
| 31 to 16 | HCVERSION [15:0] | Host Controller Interface Version Number: This field contains a BCD encoded version number of the interface to which the Host Controller interface conforms. |
| 15 to 8 | reserved | - |
| 7 to 0 | CAPLENGTH [7:0] | Capability Register Length: This is used as an offset. It is added to the register base to find the beginning of the operational register space. |

11.2.2 HCSPARAMS register

The Host Controller Structural Parameters (HCSPARAMS) register is a set of fields that are structural parameters. The bit allocation is given in [Table 88](#).

Table 88: HCSPARAMS - Host Controller Structural Parameters register bit allocation

Address: Value read from func2 of address 10h + 04h

| | | | | | | | | |
|---------------|-----------|-----------|-----------|-----------|-----------|-----------|-----------|-----------|
| Bit | 31 | 30 | 29 | 28 | 27 | 26 | 25 | 24 |
| Symbol | reserved | | | | | | | |
| Reset | 0 | 0 | 0 | 0 | 0 | 0 | 0 | 0 |
| Access | R | R | R | R | R | R | R | R |
| Bit | 23 | 22 | 21 | 20 | 19 | 18 | 17 | 16 |
| Symbol | reserved | | | | | | | |
| Reset | 0 | 0 | 0 | 0 | 0 | 0 | 0 | 0 |
| Access | R | R | R | R | R | R | R | R |

| Bit | 15 | 14 | 13 | 12 | 11 | 10 | 9 | 8 |
|--------|-----------|----------|----|-----|--------------|----|---|---|
| Symbol | N_CC[3:0] | | | | N_PCC[3:0] | | | |
| Reset | 0 | 0 | 1 | 0 | 0 | 0 | 0 | 1 |
| Access | R | R | R | R | R | R | R | R |
| Bit | 7 | 6 | 5 | 4 | 3 | 2 | 1 | 0 |
| Symbol | PRR | reserved | | PPC | N_PORTS[3:0] | | | |
| Reset | 1 | 0 | 0 | 1 | 0 | 0 | 1 | 0 |
| Access | R | R | R | R | R | R | R | R |

Table 89: HCSPARAMS - Host Controller Structural Parameters register bit description

Address: Value read from func2 of address 10h + 04h

| Bit | Symbol | Description |
|----------|---------------|---|
| 31 to 16 | reserved | - |
| 15 to 12 | N_CC [3:0] | Number of Companion Controller: This field indicates the number of companion controllers associated with this Hi-Speed USB Host Controller. A value of zero in this field indicates there are no companion Host Controllers. Port-ownership hand-off is not supported. Only high-speed devices are supported on the Host Controller root ports. A value larger than zero in this field indicates there are companion Original USB Host Controller(s). Port-ownership hand-offs are supported. |
| 11 to 8 | N_PCC [3:0] | Number of Ports per Companion Controller: This field indicates the number of ports supported per companion Host Controller. It is used to indicate the port routing configuration to the system software. For example, if N_PORTS has a value of 6 and N_CC has a value of 2, then N_PCC can have a value of 3. The convention is that the first N_PCC ports are assumed to be routed to companion controller 1, the next N_PCC ports to companion controller 2, and so on. In the previous example, N_PCC could have been 4, in which case the first four are routed to companion controller 1 and the last two are routed to companion controller 2. The number in this field must be consistent with N_PORTS and N_CC. |
| 7 | PRR | Port Routing Rules: This field indicates the method used to map ports to companion controllers. 0 — The first N_PCC ports are routed to the lowest numbered function companion Host Controller, the next N_PCC ports are routed to the next lowest function companion controller, and so on. 1 — The port routing is explicitly enumerated by the first N_PORTS elements of the HCSP-PORTROUTE array. |
| 6 to 5 | reserved | - |
| 4 | PPC | Port Power Control: This field indicates whether the Host Controller implementation includes port power control. Logic 1 indicates the port has port power switches. Logic 0 indicates the port does not have port power switches. The value of this field affects the functionality of the Port Power field in each port status and control register. |
| 3 to 0 | N_PORTS [3:0] | N_Ports: This field specifies the number of physical downstream ports implemented on this Host Controller. The value in this field determines how many port registers are addressable in the operational register space. Logic 0 in this field is undefined. |

11.2.3 HCCPARAMS register

The Host Controller Capability Parameters (HCCPARAMS) register is a 4 B register, and the bit allocation is given in [Table 90](#).

Table 90: HCCPARAMS - Host Controller Capability Parameters register bit allocation

Address: Value read from func2 of address 10h + 08h

| Bit | 31 | 30 | 29 | 28 | 27 | 26 | 25 | 24 |
|--------|----------|----|----|----------|----|----|------|------|
| Symbol | reserved | | | | | | | |
| Reset | 0 | 0 | 0 | 0 | 0 | 0 | 0 | 0 |
| Access | R | R | R | R | R | R | R | R |
| Bit | 23 | 22 | 21 | 20 | 19 | 18 | 17 | 16 |
| Symbol | reserved | | | | | | | |
| Reset | 0 | 0 | 0 | 0 | 0 | 0 | 0 | 0 |
| Access | R | R | R | R | R | R | R | R |
| Bit | 15 | 14 | 13 | 12 | 11 | 10 | 9 | 8 |
| Symbol | reserved | | | | | | | |
| Reset | 0 | 0 | 0 | 0 | 0 | 0 | 0 | 0 |
| Access | R | R | R | R | R | R | R | R |
| Bit | 7 | 6 | 5 | 4 | 3 | 2 | 1 | 0 |
| Symbol | IST[3:0] | | | reserved | | | PFLF | 64AC |
| Reset | 0 | 0 | 0 | 1 | 0 | 0 | 1 | 0 |
| Access | R | R | R | R | R | R | R | R |

Table 91: HCCPARAMS - Host Controller Capability Parameters register bit description

Address: Value read from func2 of address 10h + 08h

| Bit | Symbol | Description |
|---------|----------|---|
| 31 to 8 | reserved | - |
| 7 to 4 | IST[3:0] | Isochronous Scheduling Threshold: Default = implementation dependent. This field indicates—relative to the current position of the executing Host Controller—where software can reliably update the isochronous schedule. When IST[3] is logic 0, the value of the least significant three bits indicates the number of micro frames a Host Controller can hold a set of isochronous data structures—one or more—before flushing the state. When IST[3] is logic 1, the host software assumes the Host Controller may cache an isochronous data structure for an entire frame. |
| 3 to 2 | reserved | - |
| 1 | PFLF | Programmable Frame List Flag: Default = implementation dependent. If this bit is cleared, the system software must use a frame list length of 1024 elements with the Host Controller. The USBCMD register FLS[1:0] (bits 3 and 2) is read-only and should be cleared. If PFLF is set, the system software can specify and use a smaller frame list and configure the host through the FLS bit. The frame list must always be aligned on a 4 kB page boundary to ensure that the frame list is always physically contiguous. |
| 0 | 64AC | 64-bit Addressing Capability: This field contains the addressing range capability. 0 — Data structures using 32-bit address memory pointers 1 — Data structures using 64-bit address memory pointers. |

11.2.4 HCSP-PORTROUTE register

The HCSP-PORTROUTE (Companion Port Route Description) register is an optional read-only field that is valid only if PRR (bit 7 in the HCSPARAMS register) is logic 1. Its address is value read from func2 of address 10h + 0Ch.

This field is a 15-element nibble array—each 4 bits is one array element. Each array location corresponds one-to-one with a physical port provided by the Host Controller. For example, PORTROUTE[0] corresponds to the first PORTSC port, PORTROUTE[1] to the second PORTSC port, and so on. The value of each element indicates to which of the companion Host Controllers this port is routed. Only the first N_PORTS elements have valid information. A value of zero indicates that the port is routed to the lowest numbered function companion Host Controller. A value of one indicates that the port is routed to the next lowest numbered function companion Host Controller, and so on.

11.3 Operational registers of Enhanced USB Host Controller

11.3.1 USBCMD register

The USB Command (USBCMD) register indicates the command to be executed by the serial Host Controller. Writing to this register causes a command to be executed. [Table 92](#) shows the bit allocation.

Table 92: USBCMD - USB Command register bit allocation

Address: Value read from func2 of address 10h + 20h

| | | | | | | | | |
|---------------|-------------------------|-----------|-----------|-----------|-----------|-----------|-------------|-----------|
| Bit | 31 | 30 | 29 | 28 | 27 | 26 | 25 | 24 |
| Symbol | reserved ^[1] | | | | | | | |
| Reset | 0 | 0 | 0 | 0 | 0 | 0 | 0 | 0 |
| Access | R/W | R/W | R/W | R/W | R/W | R/W | R/W | R/W |
| Bit | 23 | 22 | 21 | 20 | 19 | 18 | 17 | 16 |
| Symbol | ITC[7:0] | | | | | | | |
| Reset | 0 | 0 | 0 | 0 | 1 | 0 | 0 | 0 |
| Access | R/W | R/W | R/W | R/W | R/W | R/W | R/W | R/W |
| Bit | 15 | 14 | 13 | 12 | 11 | 10 | 9 | 8 |
| Symbol | reserved ^[1] | | | | | | | |
| Reset | 0 | 0 | 0 | 0 | 0 | 0 | 0 | 0 |
| Access | R/W | R/W | R/W | R/W | R/W | R/W | R/W | R/W |
| Bit | 7 | 6 | 5 | 4 | 3 | 2 | 1 | 0 |
| Symbol | LHCR | IAAD | ASE | PSE | FLS[1:0] | | HC RESET | RS |
| Reset | 0 | 0 | 0 | 0 | 0 | 0 | 0 | 0 |
| Access | R/W | R/W | R/W | R/W | R/W | R/W | R/W | R/W |

[1] The reserved bits should always be written with the reset value.

Table 93: USBCMD - USB Command register bit description

Address: Value read from func2 of address 10h + 20h

| Bit | Symbol | Description |
|----------|----------|---|
| 31 to 24 | reserved | - |
| 23 to 16 | ITC[7:0] | <p>Interrupt Threshold Control: Default = 08h. This field is used by the system software to select the maximum rate at which the Host Controller will issue interrupts. If software writes an invalid value to this register, the results are undefined. Valid values are:</p> <p>00h — reserved 01h — 1 micro frame 02h — 2 micro frames 04h — 4 micro frames 08h — 8 micro frames (equals 1 ms) 10h — 16 micro frames (equals 2 ms) 20h — 32 micro frames (equals 4 ms) 40h — 64 micro frames (equals 8 ms).</p> <p>Software modifications to this field while HCH (bit 12) in the USBSTS register is zero results in undefined behavior.</p> |
| 15 to 8 | reserved | - |
| 7 | LHCR | <p>Light Host Controller Reset: This control bit is not required. It allows the driver software to reset the EHCI controller, without affecting the state of the ports or the relationship to the companion Host Controllers. If not implemented, a read of this field will always return zero. If implemented, on read:</p> <p>0 — Indicates that the Light Host Controller Reset has completed and it is ready for the host software to reinitialize the Host Controller 1 — Indicates that the Light Host Controller Reset has not yet completed.</p> |
| 6 | IAAD | <p>Interrupt on Asynchronous Advance Doorbell: This bit is used as a doorbell by software to notify the Host Controller to issue an interrupt the next time it advances the asynchronous schedule. Software must write logic 1 to this bit to ring the doorbell. When the Host Controller has evicted all appropriate cached schedule states, it sets IAA (bit 5 in the USBSTS register). If IAAE (bit 5 in the USBINTR register) is logic 1, then the Host Controller will assert an interrupt at the next interrupt threshold. The Host Controller sets this bit to logic 0 after it sets IAA. Software should not set this bit when the asynchronous schedule is inactive because this results in an undefined value.</p> |

Table 93: USBCMD - USB Command register bit description...continued

Address: Value read from func2 of address 10h + 20h

| Bit | Symbol | Description |
|--------|----------|---|
| 5 | ASE | Asynchronous Schedule Enable: Default = 0. This bit controls whether the Host Controller skips processing the asynchronous schedule. 0 — Do not process the asynchronous schedule 1 — Use the ASYNCLISTADDR register to access the asynchronous schedule. |
| 4 | PSE | Periodic Schedule Enable: Default = 0. This bit controls whether the Host Controller skips processing the periodic schedule. 0 — Do not process the periodic schedule 1 — Use the PERIODICLISTBASE register to access the periodic schedule. |
| 3 to 2 | FLS[1:0] | Frame List Size: Default = 00b. This field is read and write only if PFLF (bit 1) in the HCCPARAMS register is set to logic 1. This field specifies the size of the frame list. The size the frame list controls which bits in the Frame Index register should be used for the frame list current index. 00b — 1024 elements (4096 B) 01b — 512 elements (2048 B) 10b — 256 elements (1024 B) for small environments 11b — reserved. |
| 1 | HCRESET | Host Controller Reset: This control bit is used by the software to reset the Host Controller. The effects of this on Root Hub registers are similar to a chip hardware reset. Setting this bit causes the Host Controller to reset its internal pipelines, timers, counters, state machines, and so on, to their initial values. Any transaction currently in progress on USB is immediately terminated. A USB reset is not driven on downstream ports. This reset does not affect the PCI Configuration registers. All operational registers, including port registers and port state machines, are set to their initial values. Port ownership reverts to the companion Host Controller(s). The software must reinitialize the Host Controller to return it to an operational state. This bit is cleared by the Host Controller when the reset process is complete. Software cannot terminate the reset process early by writing logic 0 to this register. Software should check that bit HCH is logic 0 before setting this bit. Attempting to reset an actively running Host Controller results in undefined behavior. |
| 0 | RS | Run/Stop: 1 = Run. 0 = Stop. When set, the Host Controller executes the schedule. The Host Controller continues execution as long as this bit is set. When this bit is cleared, the Host Controller completes the current and active transactions in the USB pipeline, and then halts. Bit HCH indicates when the Host Controller has finished the transaction and has entered the stopped state. Software should check that the HCH bit is logic 1, before setting this bit. |

11.3.2 USBSTS register

The USB Status (USBSTS) register indicates pending interrupts and various states of the Host Controller. The status resulting from a transaction on the serial bus is not indicated in this register. Software clears the register bits by writing ones to them. The bit allocation is given in [Table 94](#).

Table 94: USBSTS - USB Status register bit allocation

Address: Value read from func2 of address 10h + 24h

| | | | | | | | | |
|---------------|--------------|-----------|-----------|-----------|--------------|-----------|---------------|-----------|
| Bit | 31 | 30 | 29 | 28 | 27 | 26 | 25 | 24 |
| Symbol | reserved [1] | | | | | | | |
| Reset | 0 | 0 | 0 | 0 | 0 | 0 | 0 | 0 |
| Access | R/W | R/W | R/W | R/W | R/W | R/W | R/W | R/W |
| Bit | 23 | 22 | 21 | 20 | 19 | 18 | 17 | 16 |
| Symbol | reserved [1] | | | | | | | |
| Reset | 0 | 0 | 0 | 0 | 0 | 0 | 0 | 0 |
| Access | R/W | R/W | R/W | R/W | R/W | R/W | R/W | R/W |
| Bit | 15 | 14 | 13 | 12 | 11 | 10 | 9 | 8 |
| Symbol | ASS | PSSTAT | RECL | HCH | reserved [1] | | | |
| Reset | 0 | 0 | 0 | 1 | 0 | 0 | 0 | 0 |
| Access | R | R | R | R | R/W | R/W | R/W | R/W |
| Bit | 7 | 6 | 5 | 4 | 3 | 2 | 1 | 0 |
| Symbol | reserved [1] | | IAA | HSE | FLR | PCD | USB ERRINT | USBINT |
| Reset | 0 | 0 | 0 | 0 | 0 | 0 | 0 | 0 |
| Access | R/W | R/W | R | R/W | R/W | R/W | R/W | R/W |

[1] The reserved bits should always be written with the reset value.

Table 95: USBSTS - USB Status register bit description

Address: Value read from func2 of address 10h + 24h

| Bit | Symbol | Description |
|----------|----------|---|
| 31 to 16 | reserved | - |
| 15 | ASS | Asynchronous Schedule Status: Default = 0. The bit reports the current real status of the asynchronous schedule. If this bit is logic 0, the status of the asynchronous schedule is disabled. If this bit is logic 1, the status of the asynchronous schedule is enabled. The Host Controller is not required to immediately disable or enable the asynchronous schedule when software changes ASE (bit 5 in the USBCMD register). When this bit and the ASE bit have the same value, the asynchronous schedule is either enabled (1) or disabled (0). |
| 14 | PSSTAT | Periodic Schedule Status: Default = 0. This bit reports the current status of the periodic schedule. If this bit is logic 0, the status of the periodic schedule is disabled. If this bit is logic 1, the status of the periodic schedule is enabled. The Host Controller is not required to immediately disable or enable the periodic schedule when software changes PSE (bit 4) in the USBCMD register. When this bit and the PSE bit have the same value, the periodic schedule is either enabled (1) or disabled (0). |
| 13 | RECL | Reclamation: Default = 0. This is a read-only status bit that is used to detect an empty asynchronous schedule. |
| 12 | HCH | HCHalted: Default = 1. This bit is logic 0 when RS (bit 0) in the USBCMD register is logic 1. The Host Controller sets this bit to logic 1 after it has stopped executing because the RS bit is set to logic 0, either by software or by the Host Controller hardware. For example, on an internal error. |

Table 95: USBSTS - USB Status register bit description...continued

Address: Value read from func2 of address 10h + 24h

| Bit | Symbol | Description |
|---------|---------------|--|
| 11 to 6 | reserved | - |
| 5 | IAA | Interrupt on Asynchronous Advance: Default = 0. The system software can force the Host Controller to issue an interrupt the next time the Host Controller advances the asynchronous schedule by writing logic 1 to IAAD (bit 6) in the USBCMD register. This status bit indicates the assertion of that interrupt source. |
| 4 | HSE | Host System Error: The Host Controller sets this bit when a serious error occurs during a host system access, involving the Host Controller module. In a PCI system, conditions that set this bit include PCI parity error, PCI master abort and PCI target abort. When this error occurs, the Host Controller clears RS (bit 0 in the USBCMD register) to prevent further execution of the scheduled TDs. |
| 3 | FLR | Frame List Rollover: The Host Controller sets this bit to logic 1 when the frame list index rolls over from its maximum value to zero. The exact value at which the rollover occurs depends on the frame list size. For example, if the frame list size—as programmed in FLS (bits 3 to 2) of the USBCMD register—is 1024, the Frame Index register rolls over every time bit 13 of the FRINDEX register toggles. Similarly, if the size is 512, the Host Controller sets this bit to logic 1 every time bit 12 of the FRINDEX register toggles. |
| 2 | PCD | Port Change Detect: The Host Controller sets this bit to logic 1 when any port—where PO (bit 13 of PORTSC) is cleared—changes to logic 1, or FPR (bit 6 of PORTSC) changes to logic 1 as a result of a J-K transition detected on a suspended port. This bit is allowed to be maintained in the auxiliary power well. Alternatively, it is also acceptable that—on a D3-to-D0 transition of the EHCI Host Controller device—this bit is loaded with the logical OR of all the PORTSC change bits, including force port resume, overcurrent change, enable or disable change, and connect status change. |
| 1 | USBERR INT | USB Error Interrupt: The Host Controller sets this bit when an error condition occurs because of completing a USB transaction. For example, error counter underflow. If the Transfer Descriptor (TD) on which the error interrupt occurred also had its IOC bit set, both this bit and the USBINT bit are set. For details, refer to the <i>Enhanced Host Controller Interface Specification for Universal Serial Bus Rev. 1.0</i> . |
| 0 | USBINT | USB Interrupt: The Host Controller sets this bit on completing a USB transaction, which results in the retirement of a TD that had its IOC bit set. The Host Controller also sets this bit when a short packet is detected, that is, the actual number of bytes received was less than the expected number of bytes. For details, refer to the <i>Enhanced Host Controller Interface Specification for Universal Serial Bus Rev. 1.0</i> . |

11.3.3 USBINTR register

The USB Interrupt Enable (USBINTR) register enables and disables reporting of the corresponding interrupt to the software. When a bit is set and the corresponding interrupt is active, an interrupt is generated to the host. Interrupt sources that are disabled in this register still appear in USBSTS to allow the software to poll for events. The USBSTS register bit allocation is given in [Table 96](#).

Table 96: USBINTR - USB Interrupt Enable register bit allocation

Address: Value read from func2 of address 10h + 28h

| | | | | | | | | |
|---------------|--------------|-----------|-----------|-----------|-----------|-----------|----------------|-----------|
| Bit | 31 | 30 | 29 | 28 | 27 | 26 | 25 | 24 |
| Symbol | reserved [1] | | | | | | | |
| Reset | 0 | 0 | 0 | 0 | 0 | 0 | 0 | 0 |
| Access | R/W | R/W | R/W | R/W | R/W | R/W | R/W | R/W |
| Bit | 23 | 22 | 21 | 20 | 19 | 18 | 17 | 16 |
| Symbol | reserved [1] | | | | | | | |
| Reset | 0 | 0 | 0 | 0 | 0 | 0 | 0 | 0 |
| Access | R/W | R/W | R/W | R/W | R/W | R/W | R/W | R/W |
| Bit | 15 | 14 | 13 | 12 | 11 | 10 | 9 | 8 |
| Symbol | reserved [1] | | | | | | | |
| Reset | 0 | 0 | 0 | 0 | 0 | 0 | 0 | 0 |
| Access | R/W | R/W | R/W | R/W | R/W | R/W | R/W | R/W |
| Bit | 7 | 6 | 5 | 4 | 3 | 2 | 1 | 0 |
| Symbol | reserved [1] | | IAAE | HSEE | FLRE | PCIE | USBERR INTE | USBINTE |
| Reset | 0 | 0 | 0 | 0 | 0 | 0 | 0 | 0 |
| Access | R/W | R/W | R/W | R/W | R/W | R/W | R/W | R/W |

[1] The reserved bits should always be written with the reset value.

Table 97: USBINTR - USB Interrupt Enable register bit description

Address: Value read from func2 of address 10h + 28h

| Bit | Symbol | Description |
|---------|----------------|---|
| 31 to 6 | reserved | - |
| 5 | IAAE | Interrupt on Asynchronous Advance Enable: When this bit and IAA (bit 5 in the USBSTS register) are set, the Host Controller issues an interrupt at the next interrupt threshold. The interrupt is acknowledged by software clearing bit IAA. |
| 4 | HSEE | Host System Error Enable: When this bit and HSE (bit 4 in the USBSTS register) are set, the Host Controller issues an interrupt. The interrupt is acknowledged by software clearing bit HSE. |
| 3 | FLRE | Frame List Rollover Enable: When this bit and FLR (bit 3 in the USBSTS register) are set, the Host Controller issues an interrupt. The interrupt is acknowledged by software clearing bit FLR. |
| 2 | PCIE | Port Change Interrupt Enable: When this bit and PCD (bit 2 in the USBSTS register) are set, the Host Controller issues an interrupt. The interrupt is acknowledged by software clearing bit PCD. |
| 1 | USB ERRINTE | USB Error Interrupt Enable: When this bit and USBERRINT (bit 1 in the USBSTS register) are set, the Host Controller issues an interrupt at the next interrupt threshold. The interrupt is acknowledged by software clearing bit USBERRINT. |
| 0 | USBINTE | USB Interrupt Enable: When this bit and USBINT (bit 0 in the USBSTS register) are set, the Host Controller issues an interrupt at the next interrupt threshold. The interrupt is acknowledged by software clearing bit USBINT. |

11.3.4 FRINDEX register

The Frame Index (FRINDEX) register is used by the Host Controller to index into the periodic frame list. The register updates every 125 μ s—once each micro frame. Bits N to 3 are used to select a particular entry in the periodic frame list during periodic schedule execution. The number of bits used for the index depends on the size of the frame list as set by the system software in FLS[1:0] (bits 3 to 2) of the USBCMD register. This register must be written as a DWord. Byte writes produce undefined results. This register cannot be written unless the Host Controller is in the halted state, as indicated by HCH (bit 12 in the USBSTS register). A write to this register while RS (bit 0 in the USBCMD register) is set produces undefined results. Writes to this register also affect the SOF value.

The bit allocation is given in [Table 98](#).

Table 98: FRINDEX - Frame Index register bit allocation

Address: Value read from func2 of address 10h + 2Ch

| | | | | | | | | |
|---------------|-------------------------|-----------|---------------|-----------|-----------|-----------|-----------|-----------|
| Bit | 31 | 30 | 29 | 28 | 27 | 26 | 25 | 24 |
| Symbol | reserved ^[1] | | | | | | | |
| Reset | 0 | 0 | 0 | 0 | 0 | 0 | 0 | 0 |
| Access | R/W | R/W | R/W | R/W | R/W | R/W | R/W | R/W |
| Bit | 23 | 22 | 21 | 20 | 19 | 18 | 17 | 16 |
| Symbol | reserved ^[1] | | | | | | | |
| Reset | 0 | 0 | 0 | 0 | 0 | 0 | 0 | 0 |
| Access | R/W | R/W | R/W | R/W | R/W | R/W | R/W | R/W |
| Bit | 15 | 14 | 13 | 12 | 11 | 10 | 9 | 8 |
| Symbol | reserved ^[1] | | FRINDEX[13:8] | | | | | |
| Reset | 0 | 0 | 0 | 0 | 0 | 0 | 0 | 0 |
| Access | R/W | R/W | R/W | R/W | R/W | R/W | R/W | R/W |
| Bit | 7 | 6 | 5 | 4 | 3 | 2 | 1 | 0 |
| Symbol | FRINDEX[7:0] | | | | | | | |
| Reset | 0 | 0 | 0 | 0 | 0 | 0 | 0 | 0 |
| Access | R/W | R/W | R/W | R/W | R/W | R/W | R/W | R/W |

[1] The reserved bits should always be written with the reset value.

Table 99: FRINDEX - Frame Index register bit description

Address: Value read from func2 of address 10h + 2Ch

| Bit | Symbol | Description | | | | | | | | | | | | | | | |
|----------|-----------------|---|----------|-----------------|---|-----|------|----|-----|-----|----|-----|-----|----|-----|----------|---|
| 31 to 14 | reserved | - | | | | | | | | | | | | | | | |
| 13 to 0 | FRINDEX [13:0] | <p>Frame Index: Bits in this register are used for the frame number in the SOF packet and as the index into the frame list. The value in this register increments at the end of each time frame. For example, micro frame. The bits used for the frame number in the SOF token are taken from bits 13 to 3 of this register. Bits N to 3 are used for the frame list current index. This means that each location of the frame list is accessed eight times—frames or micro frames—before moving to the next index.</p> <p>The following illustrates values of N based on the value of FLS[1:0] (bits 3 to 2 in the USBCMD register).</p> <table border="1" style="margin-left: auto; margin-right: auto;"> <thead> <tr> <th>FLS[1:0]</th> <th>Number elements</th> <th>N</th> </tr> </thead> <tbody> <tr> <td>00b</td> <td>1024</td> <td>12</td> </tr> <tr> <td>01b</td> <td>512</td> <td>11</td> </tr> <tr> <td>10b</td> <td>256</td> <td>10</td> </tr> <tr> <td>11b</td> <td>reserved</td> <td>-</td> </tr> </tbody> </table> | FLS[1:0] | Number elements | N | 00b | 1024 | 12 | 01b | 512 | 11 | 10b | 256 | 10 | 11b | reserved | - |
| FLS[1:0] | Number elements | N | | | | | | | | | | | | | | | |
| 00b | 1024 | 12 | | | | | | | | | | | | | | | |
| 01b | 512 | 11 | | | | | | | | | | | | | | | |
| 10b | 256 | 10 | | | | | | | | | | | | | | | |
| 11b | reserved | - | | | | | | | | | | | | | | | |

11.3.5 PERIODICLISTBASE register

The Periodic Frame List Base Address (PERIODICLISTBASE) register contains the beginning address of the periodic frame list in the system memory. If the Host Controller is in 64-bit mode—as indicated by logic 1 in 64AC (bit 0 of the HCCSPARAMS register)—the most significant 32 bits of every control data structure address comes from the CTRLDSSEGMENT register. The system software loads this register before starting the schedule execution by the Host Controller. The memory structure referenced by this physical memory pointer is assumed as 4 kB aligned. The contents of this register are combined with the FRINDEX register to enable the Host Controller to step through the periodic frame list in sequence.

The bit allocation is given in [Table 100](#).

Table 100: PERIODICLISTBASE - Periodic Frame List Base Address register bit allocation

Address: Value read from func2 of address 10h + 34h

| Bit | 31 | 30 | 29 | 28 | 27 | 26 | 25 | 24 |
|--------|-----------|-----|-----|-----|-------------------------|-----|-----|-----|
| Symbol | BA[19:12] | | | | | | | |
| Reset | 0 | 0 | 0 | 0 | 0 | 0 | 0 | 0 |
| Access | R/W | R/W | R/W | R/W | R/W | R/W | R/W | R/W |
| Bit | 23 | 22 | 21 | 20 | 19 | 18 | 17 | 16 |
| Symbol | BA[11:4] | | | | | | | |
| Reset | 0 | 0 | 0 | 0 | 0 | 0 | 0 | 0 |
| Access | R/W | R/W | R/W | R/W | R/W | R/W | R/W | R/W |
| Bit | 15 | 14 | 13 | 12 | 11 | 10 | 9 | 8 |
| Symbol | BA[3:0] | | | | reserved ^[1] | | | |
| Reset | 0 | 0 | 0 | 0 | 0 | 0 | 0 | 0 |
| Access | R/W | R/W | R/W | R/W | R/W | R/W | R/W | R/W |

| Bit | 7 | 6 | 5 | 4 | 3 | 2 | 1 | 0 |
|--------|-------------------------|-----|-----|-----|-----|-----|-----|-----|
| Symbol | reserved ^[1] | | | | | | | |
| Reset | 0 | 0 | 0 | 0 | 0 | 0 | 0 | 0 |
| Access | R/W | R/W | R/W | R/W | R/W | R/W | R/W | R/W |

[1] The reserved bits should always be written with the reset value.

Table 101: PERIODICLISTBASE - Periodic Frame List Base Address register bit description
Address: Value read from func2 of address 10h + 34h

| Bit | Symbol | Description |
|----------|----------|--|
| 31 to 12 | BA[19:0] | Base Address: These bits correspond to memory address signals 31 to 12, respectively. |
| 11 to 0 | reserved | - |

11.3.6 ASYNCLISTADDR register

This 32-bit register contains the address of the next asynchronous queue head to be executed. If the Host Controller is in 64-bit mode—as indicated by logic 1 in 64AC (bit 0 of the HCCPARAMS register)—the most significant 32 bits of every control data structure address comes from the CTRLDSSEGMENT register. Bits 4 to 0 of this register always return zeros when read. The memory structure referenced by the physical memory pointer is assumed as 32 B (cache aligned). For bit allocation, see [Table 102](#).

Table 102: ASYNCLISTADDR - Current Asynchronous List Address register bit allocation
Address: Value read from func2 of address 10h + 38h

| Bit | 31 | 30 | 29 | 28 | 27 | 26 | 25 | 24 |
|--------|-------------------------|-----|-----|-----|-------------------------|-----|-----|-----|
| Symbol | LPL[19:12] | | | | | | | |
| Reset | 0 | 0 | 0 | 0 | 0 | 0 | 0 | 0 |
| Access | R/W | R/W | R/W | R/W | R/W | R/W | R/W | R/W |
| Bit | 23 | 22 | 21 | 20 | 19 | 18 | 17 | 16 |
| Symbol | LPL[11:4] | | | | | | | |
| Reset | 0 | 0 | 0 | 0 | 0 | 0 | 0 | 0 |
| Access | R/W | R/W | R/W | R/W | R/W | R/W | R/W | R/W |
| Bit | 15 | 14 | 13 | 12 | 11 | 10 | 9 | 8 |
| Symbol | LPL[3:0] | | | | reserved ^[1] | | | |
| Reset | 0 | 0 | 0 | 0 | 0 | 0 | 0 | 0 |
| Access | R/W | R/W | R/W | R/W | R/W | R/W | R/W | R/W |
| Bit | 7 | 6 | 5 | 4 | 3 | 2 | 1 | 0 |
| Symbol | reserved ^[1] | | | | | | | |
| Reset | 0 | 0 | 0 | 0 | 0 | 0 | 0 | 0 |
| Access | R/W | R/W | R/W | R/W | R/W | R/W | R/W | R/W |

[1] The reserved bits should always be written with the reset value.

Table 103: ASYNCLISTADDR - Current Asynchronous List Address register bit description

Address: Value read from func2 of address 10h + 38h

| Bit | Symbol | Description |
|----------|-----------|--|
| 31 to 12 | LPL[19:0] | Link Pointer List: These bits correspond to memory address signals 31 to 12, respectively. This field may only reference a Queue Head (QH). |
| 11 to 0 | reserved | - |

11.3.7 CONFIGFLAG register

The bit allocation of the Configure Flag (CONFIGFLAG) register is given in [Table 104](#).

Table 104: CONFIGFLAG - Configure Flag register bit allocation

Address: Value read from func2 of address 10h + 60h

| Bit | 31 | 30 | 29 | 28 | 27 | 26 | 25 | 24 |
|--------|-------------------------|-----|-----|-----|-----|-----|-----|-----|
| Symbol | reserved ^[1] | | | | | | | |
| Reset | 0 | 0 | 0 | 0 | 0 | 0 | 0 | 0 |
| Access | R/W | R/W | R/W | R/W | R/W | R/W | R/W | R/W |
| Bit | 23 | 22 | 21 | 20 | 19 | 18 | 17 | 16 |
| Symbol | reserved ^[1] | | | | | | | |
| Reset | 0 | 0 | 0 | 0 | 0 | 0 | 0 | 0 |
| Access | R/W | R/W | R/W | R/W | R/W | R/W | R/W | R/W |
| Bit | 15 | 14 | 13 | 12 | 11 | 10 | 9 | 8 |
| Symbol | reserved ^[1] | | | | | | | |
| Reset | 0 | 0 | 0 | 0 | 0 | 0 | 0 | 0 |
| Access | R/W | R/W | R/W | R/W | R/W | R/W | R/W | R/W |
| Bit | 7 | 6 | 5 | 4 | 3 | 2 | 1 | 0 |
| Symbol | reserved ^[1] | | | | | | | CF |
| Reset | 0 | 0 | 0 | 0 | 0 | 0 | 0 | 0 |
| Access | R/W | R/W | R/W | R/W | R/W | R/W | R/W | R/W |

[1] The reserved bits should always be written with the reset value.

Table 105: CONFIGFLAG - Configure Flag register bit description

Address: Value read from func2 of address 10h + 60h

| Bit | Symbol | Description |
|---------|----------|--|
| 31 to 1 | reserved | - |
| 0 | CF | Configure Flag: The host software sets this bit as the last action in its process of configuring the Host Controller. This bit controls the default port-routing control logic. 0 — Port routing control logic default-routes each port to an implementation dependent classic Host Controller 1 — Port routing control logic default-routes all ports to this Host Controller. |

11.3.8 PORTSC registers 1, 2

The Port Status and Control (PORTSC) register is in the auxiliary power well. It is only reset by hardware when the auxiliary power is initially applied or in response to a Host Controller reset. The initial conditions of a port are:

- No device connected
- Port disabled.

If the port has power control, software cannot change the state of the port until it sets the port power bits. Software must not attempt to change the state of the port until power is stable on the port; maximum delay is 20 ms from the transition. For bit allocation, see [Table 106](#).

Table 106: PORTSC 1, 2 - Port Status and Control 1, 2 register bit allocation

Address: Value read from func2 of address 10h + 64h + (4 x Port Number – 1) where Port Number is 1, 2

| Bit | 31 | 30 | 29 | 28 | 27 | 26 | 25 | 24 |
|--------|-------------------------|--------|----------------|--------------|----------|-----|-------------------------|------|
| Symbol | reserved ^[1] | | | | | | | |
| Reset | 0 | 0 | 0 | 0 | 0 | 0 | 0 | 0 |
| Access | R/W | R/W | R/W | R/W | R/W | R/W | R/W | R/W |
| Bit | 23 | 22 | 21 | 20 | 19 | 18 | 17 | 16 |
| Symbol | reserved | WKOC_E | WKDS CNNT_E | WKCNTT_ E | PTC[3:0] | | | |
| Reset | 0 | 0 | 0 | 0 | 0 | 0 | 0 | 0 |
| Access | R/W | R/W | R/W | R/W | R/W | R/W | R/W | R/W |
| Bit | 15 | 14 | 13 | 12 | 11 | 10 | 9 | 8 |
| Symbol | reserved ^[1] | | PO | PP | LS[1:0] | | reserved ^[1] | PR |
| Reset | 0 | 0 | 1 | 0 | 0 | 0 | 0 | 0 |
| Access | R/W | R/W | R/W | R/W | R/W | R/W | R/W | R |
| Bit | 7 | 6 | 5 | 4 | 3 | 2 | 1 | 0 |
| Symbol | SUSP | FPR | OCC | OCA | PEDC | PED | ECSC | ECCS |
| Reset | 0 | 0 | 0 | 0 | 0 | 0 | 0 | 0 |
| Access | R/W | R/W | R | R | R/W | R/W | R/W | R |

[1] The reserved bits should always be written with the reset value.

Table 107: PORTSC 1, 2 - Port Status and Control 1, 2 register bit description

Address: Value read from func2 of address 10h + 64h + (4 x Port Number – 1) where Port Number is 1, 2

| Bit | Symbol | Description |
|----------|----------------|---|
| 31 to 23 | reserved | - |
| 22 | WKOC_E | Wake on Overcurrent Enable: Default = 0. Setting this bit enables the port to be sensitive to overcurrent conditions as wake-up events. ^[1] |
| 21 | WKDS CNNT_E | Wake on Disconnect Enable: Default = 0. Setting this bit enables the port to be sensitive to device disconnects as wake-up events. ^[1] |
| 20 | WKCNTT_ _E | Wake on Connect Enable: Default = 0. Setting this bit enables the port to be sensitive to device connects as wake-up events. ^[1] |

Table 107: PORTSC 1, 2 - Port Status and Control 1, 2 register bit description...continued
 Address: Value read from func2 of address 10h + 64h + (4 x Port Number – 1) where Port Number is 1, 2

| Bit | Symbol | Description |
|----------|----------|---|
| 19 to 16 | PTC[3:0] | <p>Port Test Control: Default = 0000b. When this field is logic 0, the port is not operating in test mode. A nonzero value indicates that it is operating in test mode and test mode is indicated by the value. The encoding of the test mode bits are:</p> <p>0000b — Test mode disabled 0001b — Test J_STATE 0010b — Test K_STATE 0011b — Test SE0_NAK 0100b — Test packet 0101b — Test FORCE_ENABLE 0110b to 1111b — reserved.</p> |
| 15 to 14 | reserved | - |
| 13 | PO | <p>Port Owner: Default = 1. This bit unconditionally goes to logic 0 when CF (bit 0) in the CONFIGFLAG register makes logic 0 to logic 1 transition. This bit unconditionally goes to logic 1 when the CF bit is logic 0. The system software uses this field to release ownership of the port to a selected Host Controller, if the attached device is not a high-speed device. Software writes logic 1 to this bit, if the attached device is not a high-speed device. Logic 1 in this bit means that a companion Host Controller owns and controls the port.</p> |
| 12 | PP | <p>Port Power: The function of this bit depends on the value of PPC (bit 4) in the HCSPARAMS register.</p> <p>If PPC = 0 and PP = 1 — The Host Controller does not have port power control switches. Always powered.</p> <p>If PPC = 1 and PP = 1 or 0 — The Host Controller has port power control switches. This bit represents the current setting of the switch: logic 0 = off, logic 1 = on. When PP is logic 0, the port is nonfunctional and will not report any status.</p> <p>When an overcurrent condition is detected on a powered port and PPC is logic 1, the PP bit in each affected port may be changed by the Host Controller from logic 1 to logic 0, removing power from the port.</p> |
| 11 to 10 | LS[1:0] | <p>Line Status: This field reflects the current logical levels of the DP (bit 11) and DM (bit 10) signal lines. These bits are used to detect low-speed USB devices before the port reset and enable sequence. This field is valid only when the Port Enable bit is logic 0, and the Current Connect Status bit is set to logic 1.</p> <p>00b — SE0: Not a low-speed device, perform EHCI reset 01b — K-state: Low-speed device, release ownership of port 10b — J-state: Not a low-speed device, perform EHCI reset 11b — Undefined: Not a low-speed device, perform EHCI reset.</p> <p>If the PP bit is logic 0, this field is undefined.</p> |
| 9 | reserved | - |

Table 107: PORTSC 1, 2 - Port Status and Control 1, 2 register bit description...continued

Address: Value read from func2 of address $10h + 64h + (4 \times \text{Port Number} - 1)$ where Port Number is 1, 2

| Bit | Symbol | Description |
|-----|--------|---|
| 8 | PR | <p>Port Reset: Logic 1 means the port is in reset. Logic 0 means the port is not in reset. Default = 0. When software sets this bit from logic 0, the bus reset sequence as defined in <i>Universal Serial Bus Specification Rev. 2.0</i> is started. Software clears this bit to terminate the bus reset sequence. Software must hold this bit at logic 1 until the reset sequence, as specified in <i>Universal Serial Bus Specification Rev. 2.0</i>, is completed.</p> <p>Remark: When software sets this bit, it must also clear the Port Enable bit.</p> <p>Remark: When software clears this bit, there may be a delay before the bit status changes to logic 0 because it will not read logic 0 until the reset is completed. If the port is in high-speed mode after reset is completed, the Host Controller will automatically enable this port; it can set the Port Enable bit. A Host Controller must terminate the reset and stabilize the state of the port within 2 ms of software changing this bit from logic 1 to logic 0. For example, if the port detects that the attached device is high-speed during a reset, then the Host Controller must enable the port within 2 ms of software clearing this bit.</p> <p>HCH (bit 12) in the USBSTS register must be logic 0 before software attempts to use this bit. The Host Controller may hold Port Reset asserted when the HCH bit is set. [1]</p> |
| 7 | SUSP | <p>Suspend: Default = 0. Logic 1 means the port is in the suspend state. Logic 0 means the port is not suspended. The PED (Port Enabled) bit and this bit define the port states as follows:</p> <p>PED = 0 and SUSP = X — Port is disabled</p> <p>PED = 1 and SUSP = 0 — Port is enabled</p> <p>PED = 1 and SUSP = 1 — Port is suspended.</p> <p>When in the suspend state, downstream propagation of data is blocked on this port, except for the port reset. If a transaction was in progress when this bit was set, blocking occurs at the end of the current transaction. In the suspend state, the port is sensitive to resume detection. The bit status does not change until the port is suspended and there may be a delay in suspending a port, if there is a transaction currently in progress on the USB. Attempts to clear this bit are ignored by the Host Controller. The Host Controller will unconditionally set this bit to logic 0 when:</p> <ul style="list-style-type: none"> • Software changes the FPR (Force Port Resume) bit to logic 0. • Software changes the PR (Port Reset) bit to logic 1. <p>If the host software sets this bit when the Port Enabled bit is logic 0, the results are undefined. [1]</p> |

Table 107: PORTSC 1, 2 - Port Status and Control 1, 2 register bit description...continued
 Address: Value read from func2 of address $10h + 64h + (4 \times \text{Port Number} - 1)$ where Port Number is 1, 2

| Bit | Symbol | Description |
|-----|--------|--|
| 6 | FPR | Force Port Resume: Logic 1 means resume detected or driven on the port. Logic 0 means no resume (K-state) detected or driven on the port. Default = 0. Software sets this bit to drive the resume signaling. The Host Controller sets this bit if a J-to-K transition is detected, while the port is in the suspend state. When this bit changes to logic 1 because a J-to-K transition is detected, PCD (bit 2) in the USBSTS register is also set to logic 1. If software sets this bit to logic 1, the Host Controller must not set the PCD bit. When the EHCI controller owns the port, the resume sequence follows the sequence specified in <i>Universal Serial Bus Specification Rev. 2.0</i> . The resume signaling (full-speed 'K') is driven on the port as long as this bit remains set. Software must time the resume and clear this bit after the correct amount of time has elapsed. Clearing this bit causes the port to return to high-speed mode, forcing the bus below the port into a high-speed idle. This bit will remain at logic 1, until the port has switched to the high-speed idle. The Host Controller must complete this transition within 2 ms of software clearing this bit. [1] |
| 5 | OCC | Overcurrent Change: Default = 0. This bit is set to logic 1 when there is a change in overcurrent active. Software clears this bit by setting it to logic 1. |
| 4 | OCA | Overcurrent Active: Default = 0. If set to logic 1, this port has an overcurrent condition. If set to logic 0, this port does not have an overcurrent condition. This bit will automatically change from logic 1 to logic 0 when the overcurrent condition is removed. |
| 3 | PEDC | Port Enable/Disable Change: Logic 1 means the port enabled or disabled status has changed. Logic 0 means no change. Default = 0. For the root hub, this bit is set only when a port is disabled because of the appropriate conditions existing at the EOF2 point. For definition of port error, refer to Chapter 11 of <i>Universal Serial Bus Specification Rev. 2.0</i> . Software clears this bit by setting it. [1] |
| 2 | PED | Port Enabled/Disabled: Logic 1 means enable. Logic 0 means disable. Default = 0. Ports can only be enabled by the Host Controller as a part of the reset and enable sequence. Software cannot enable a port by writing logic 1 to this field. The Host Controller will only set this bit when the reset sequence determines that the attached device is a high-speed device. Ports can be disabled by either a fault condition or by host software. The bit status does not change until the port state has changed. There may be a delay in disabling or enabling a port because of other Host Controller and bus events. When the port is disabled, downstream propagation of data is blocked on this port, except for reset. [1] |
| 1 | ECSC | Connect Status Change: Logic 1 means change in ECCS. Logic 0 means no change. Default = 0. This bit indicates a change has occurred in the ECCS of the port. The Host Controller sets this bit for all changes to the port device connect status, even if the system software has not cleared an existing connect status change. For example, the insertion status changes two times before the system software has cleared the changed condition, hub hardware will be setting an already-set bit, that is, the bit will remain set. Software clears this bit by writing logic 1 to it. [1] |
| 0 | ECCS | Current Connect Status: Logic 1 indicates a device is present on the port. Logic 0 indicates no device is present. Default = 0. This value reflects the current state of the port and may not directly correspond to the event that caused the ECSC bit to be set. [1] |

[1] These fields read logic 0, if the PP bit is logic 0.

12. Power consumption

[Table 108](#) shows the power consumption.

Table 108: Power consumption

| Power pins group | Conditions | Typ | Unit |
|---|--|-----|------|
| Total power | no device connected to the ISP1562 [1] | 39 | mA |
| $V_{CC(I/O_AUX)} + V_{I(VAUX3V3)} + V_{DDA_AUX} + V_{CC(I/O)} + V_{I(VREG3V3)}$ | one high-speed device connected to the ISP1562 | 58 | mA |
| | two high-speed devices connected to the ISP1562 | 76 | mA |
| Auxiliary power | no device connected to the ISP1562 [1] | 26 | mA |
| $V_{CC(I/O_AUX)} + V_{I(VAUX3V3)} + V_{DDA_AUX}$ | one high-speed device connected to the ISP1562 | 44 | mA |
| | two high-speed devices connected to the ISP1562 | 62 | mA |
| $V_{CC(I/O)} + V_{I(VREG3V3)}$ | no device connected to the ISP1562 [1] | 13 | mA |
| | one high-speed device connected to the ISP1562 | 14 | mA |
| | two high-speed devices connected to the ISP1562 | 14 | mA |

[1] When one or two full-speed or low-speed power devices are connected, the power consumption is comparable to the power consumption when no high-speed devices are connected. There is a difference of approximately 1 mA.

[Table 109](#) shows the power consumption in S1 and S3 suspend modes.

Table 109: Power consumption: S1 and S3

| Power state | Typ | Unit |
|-------------|---|------|
| S1 | 20 | mA |
| S3 | 8 [1] [2] | mA |

[1] When I²C-bus is present.

[2] For details, refer to the ISP1562 errata.

13. Limiting values

Table 110: Limiting values

In accordance with the Absolute Maximum Rating System (IEC 60134).

| Symbol | Parameter | Conditions | Min | Max | Unit |
|--------------------|---|---|------|------|------|
| $V_{CC(I/O)}$ | supply voltage to I/O pins | | -0.5 | +4.6 | V |
| $V_{I(VREG3V3)}$ | supply voltage to internal regulator | | -0.5 | +4.6 | V |
| $V_{CC(I/O)_AUX}$ | auxiliary supply voltage to I/O pins | | -0.5 | +4.6 | V |
| $V_{I(VAUX3V3)}$ | auxiliary input voltage to internal regulator | | -0.5 | +4.6 | V |
| V_{DDA_AUX} | auxiliary supply voltage for analog block | | -0.5 | +4.6 | V |
| I_{lu} | latch-up current | $V_I < 0\text{ V}$ or $V_I > V_{CC(I/O)}$ | - | 100 | mA |
| V_{esd} | electrostatic discharge voltage | all pins ($I_{LI} < 1\ \mu\text{A}$) | -4 | +4 | kV |
| T_{stg} | storage temperature | | -40 | +125 | °C |

14. Recommended operating conditions

Table 111: Recommended operating conditions

| Symbol | Parameter | Conditions | Min | Typ | Max | Unit |
|--------------------|---|------------|-----|-----|------------------------------|------|
| $V_{CC(I/O)}$ | supply voltage to I/O pins | | 3.0 | 3.3 | 3.6 | V |
| $V_{I(VREG3V3)}$ | supply voltage to internal regulator | | 3.0 | 3.3 | 3.6 | V |
| $V_{CC(I/O)_AUX}$ | auxiliary supply voltage to I/O pins | | 3.0 | 3.3 | 3.6 | V |
| $V_{I(VAUX3V3)}$ | auxiliary input voltage to internal regulator | | 3.0 | 3.3 | 3.6 | V |
| V_{DDA_AUX} | auxiliary supply voltage for analog block | | 3.0 | 3.3 | 3.6 | V |
| $V_{I(3V3)}$ | input voltage on 3.3 V buffers | | 0 | - | $V_{CC(I/O)} + 0.5\text{ V}$ | V |
| T_{amb} | ambient temperature | | -40 | - | +85 | °C |

15. Static characteristics

Table 112: Static characteristics: I²C-bus interface (SDA and SCL)

$V_{CC(I/O)} = 3.0\text{ V to }3.6\text{ V}$; $T_{amb} = -40\text{ }^{\circ}\text{C to }+85\text{ }^{\circ}\text{C}$; unless otherwise specified.

| Symbol | Parameter | Conditions | Min | Typ | Max | Unit |
|-----------------------|--------------------------|------------------------|------|-----|-----|------|
| V _{IH} | HIGH-level input voltage | | 2.1 | - | - | V |
| V _{IL} | LOW-level input voltage | | - | - | 0.9 | V |
| V _{hys} | hysteresis voltage | | 0.15 | - | - | V |
| V _{OL} | LOW-level output voltage | I _{OL} = 3 mA | - | - | 0.4 | V |
| I _{CC(susp)} | suspend supply current | | - | 1 | - | μA |

Table 113: Static characteristics: digital pins

$V_{CC(I/O)} = 3.0\text{ V to }3.6\text{ V}$; $T_{amb} = -40\text{ }^{\circ}\text{C to }+85\text{ }^{\circ}\text{C}$; unless otherwise specified.

| Symbol | Parameter | Conditions | Min | Typ | Max | Unit |
|------------------|---------------------------|------------------------|-----|-----|-----|------|
| V _{IH} | HIGH-level input voltage | | 2.0 | - | - | V |
| V _{IL} | LOW-level input voltage | | - | - | 0.8 | V |
| V _{hys} | hysteresis voltage | | 0.4 | - | 0.7 | V |
| V _{OL} | LOW-level output voltage | I _{OL} = 3 mA | - | - | 0.4 | V |
| V _{OH} | HIGH-level output voltage | | 2.4 | - | - | V |

Table 114: Static characteristics: PCI interface block

$V_{CC(I/O)} = 3.0\text{ V to }3.6\text{ V}$; $T_{amb} = -40\text{ }^{\circ}\text{C to }+85\text{ }^{\circ}\text{C}$; unless otherwise specified.

| Symbol | Parameter | Conditions | Min | Typ | Max | Unit |
|--------------------|---------------------------|---|-----|-----|-----|------|
| V _{IH} | HIGH-level input voltage | | 2.0 | - | 3.6 | V |
| V _{IL} | LOW-level input voltage | | 0 | - | 0.9 | V |
| V _{IPU} | input pull-up voltage | | 2.1 | - | - | V |
| I _{LI} | input leakage current | 0 V < V _I < V _{CC(I/O)} | -10 | - | +10 | μA |
| V _{OH} | HIGH-level output voltage | I _O = 500 μA | 2.7 | - | - | V |
| V _{OL} | LOW-level output voltage | I _O = 1500 μA | - | - | 0.3 | V |
| C _{IN} | input pin capacitance | | - | - | 10 | pF |
| C _{clk} | clock capacitance | | 5 | - | 12 | pF |
| C _{IDSEL} | IDSEL pin capacitance | | - | - | 8 | pF |

Table 115: Static characteristics: USB interface block (pins DM1 to DM2 and DP1 to DP2)

$V_{DDA_AUX} = 3.0\text{ V to }3.6\text{ V}$; $T_{amb} = -40\text{ }^{\circ}\text{C to }+85\text{ }^{\circ}\text{C}$; unless otherwise specified.

| Symbol | Parameter | Conditions | Min | Typ | Max | Unit |
|------------------------------------|--|-------------------------|-----|-----|------|------|
| Input levels for high-speed | | | | | | |
| V _{HSSQ} | squelch detection threshold (differential signal amplitude) | squelch detected | - | - | 100 | mV |
| | | no squelch detected | 150 | - | - | mV |
| V _{HSDSC} | disconnect detection threshold (differential signal amplitude) | disconnect detected | 625 | - | - | mV |
| | | disconnect not detected | - | - | 525 | mV |
| V _{HSCM} | data signaling common mode voltage range | | -50 | - | +500 | mV |

Table 115: Static characteristics: USB interface block (pins DM1 to DM2 and DP1 to DP2)...continued

$V_{DDA_AUX} = 3.0\text{ V to }3.6\text{ V}$; $T_{amb} = -40\text{ }^{\circ}\text{C to }+85\text{ }^{\circ}\text{C}$; unless otherwise specified.

| Symbol | Parameter | Conditions | Min | Typ | Max | Unit |
|---|---------------------------------------|---------------------|----------|-----|------|------|
| Output levels for high-speed | | | | | | |
| V_{HSOI} | idle state | | -10 | - | +10 | mV |
| V_{HSOH} | data signaling HIGH | | 360 | - | 440 | mV |
| V_{HSOL} | data signaling LOW | | -10 | - | +10 | mV |
| V_{CHIRPJ} | Chirp J level (differential voltage) | | 700 [1] | - | 1100 | mV |
| V_{CHIRPK} | Chirp K level (differential voltage) | | -900 [1] | - | -500 | mV |
| Input levels for full-speed and low-speed | | | | | | |
| V_{IH} | HIGH-level input voltage (drive) | | 2.0 | - | - | V |
| V_{IHZ} | HIGH-level input voltage (floating) | | 2.7 | - | 3.6 | V |
| V_{IL} | LOW-level input voltage | | - | - | 0.8 | V |
| V_{DI} | differential input sensitivity | $ V_{DP} - V_{DM} $ | 0.2 | - | - | V |
| V_{CM} | differential common mode range | | 0.8 | - | 2.5 | V |
| Output levels for full-speed and low-speed | | | | | | |
| V_{OH} | HIGH-level output voltage | | 2.8 | - | 3.6 | V |
| V_{OL} | LOW-level output voltage | | 0 | - | 0.3 | V |
| V_{OSEI} | SEI | | 0.8 | - | - | V |
| V_{CRS} | output signal crossover point voltage | | 1.3 | - | 2.0 | V |

[1] High-speed termination resistor disabled, pull-up resistor connected. Only during reset, when both the hub and device are capable of high-speed operation.

16. Dynamic characteristics

Table 116: Dynamic characteristics: system clock timing

| Symbol | Parameter | Conditions | Min | Typ | Max | Unit |
|--------------------------------|----------------------------|----------------------------|------|-----|------|---------------|
| Reset | | | | | | |
| $t_{W(\text{RESET_N})}$ | pulse width on pin RESET_N | crystal oscillator running | - | 10 | - | μs |
| Crystal oscillator | | | | | | |
| f_{clk} | PCI clock | | 31 | - | 33 | MHz |
| | external clock input [1] | crystal [2] | - | 12 | - | MHz |
| R_S | series resistance | | - | - | 100 | Ω |
| C_L | load capacitance | | - | 18 | - | pF |
| External clock input | | | | | | |
| V_I | input voltage | | 1.65 | 1.8 | 1.95 | V |
| J | external clock jitter | | - | - | 50 | ppm |
| $t_{\text{CR}}, t_{\text{CF}}$ | rise time and fall time | | - | - | 3 | ns |
| δ | clock duty cycle | | - | 50 | - | % |

[1] Recommended accuracy of the clock frequency is 50 ppm for the crystal and oscillator.

[2] Suggested values for external capacitors when using a crystal are 22 pF to 27 pF.

Table 117: Dynamic characteristics: I²C-bus interface (SDA and SCL)

$V_{\text{CC(I/O)}} = 3.0 \text{ V to } 3.6 \text{ V}$; $T_{\text{amb}} = -40 \text{ }^\circ\text{C to } +85 \text{ }^\circ\text{C}$; unless otherwise specified.

| Symbol | Parameter | Conditions | Min | Typ | Max | Unit |
|-----------------|---|----------------------|-----|-----|-----|------|
| t_{CF} | output fall time V_{IH} to V_{IL} | $10 < C_b < 400$ [1] | - | 0 | 250 | ns |

[1] The capacitive load for each bus line (C_b) is specified in pF. To meet the specification for V_{OL} and the maximum rise time (300 ns), use an external pull-up resistor with $R_{\text{UP(max)}} = 850/C_b$ k Ω and $R_{\text{UP(min)}} = (V_{\text{CC(I/O)}} - 0.4)/3$ k Ω .

Table 118: Dynamic characteristics: PCI interface block

$V_{\text{CC(I/O)}} = 3.0 \text{ V to } 3.6 \text{ V}$; $T_{\text{amb}} = -40 \text{ }^\circ\text{C to } +85 \text{ }^\circ\text{C}$; unless otherwise specified.

| Symbol | Parameter | Conditions | Min | Typ | Max | Unit |
|--------|-------------------------------|-------------------|-----|-----|-----|------|
| SR | output slew rate (rise, fall) | standard load [1] | 1 | - | 4 | V/ns |

[1] Standard load is 10 pF together with a pull-up and pull-down resistor of 10 k Ω .

Table 119: Dynamic characteristics: high-speed source electrical characteristics

$V_{\text{DDA_AUX}} = 3.0 \text{ V to } 3.6 \text{ V}$; $T_{\text{amb}} = -40 \text{ }^\circ\text{C to } +85 \text{ }^\circ\text{C}$; unless otherwise specified.

| Symbol | Parameter | Conditions | Min | Typ | Max | Unit |
|-------------------------------|--|-----------------------------|------|-----|------|----------|
| Driver characteristics | | | | | | |
| t_{HSR} | high-speed differential rise time | 10 % to 90 % | 500 | - | - | ps |
| t_{HSF} | high-speed differential fall time | 90 % to 10 % | 500 | - | - | ps |
| Z_{HSDRV} | drive output resistance; also serves as a high-speed termination | includes the R_S resistor | 40.5 | 45 | 49.5 | Ω |

Table 119: Dynamic characteristics: high-speed source electrical characteristics...continued

$V_{DDA_AUX} = 3.0\text{ V to }3.6\text{ V}$; $T_{amb} = -40\text{ }^{\circ}\text{C to }+85\text{ }^{\circ}\text{C}$; unless otherwise specified.

| Symbol | Parameter | Conditions | Min | Typ | Max | Unit |
|---------------------|---|------------|----------|-----|---------------------------|--------|
| Clock timing | | | | | | |
| t _{HSDRAT} | data rate | | 479.76 | - | 480.24 | Mbit/s |
| t _{HSFRAM} | micro frame interval | | 124.9375 | - | 125.0625 | μs |
| t _{HSRFI} | consecutive micro frame interval difference | | 1 | - | four high-speed bit times | ns |

Table 120: Dynamic characteristics: full-speed source electrical characteristics

$V_{DDA_AUX} = 3.0\text{ V to }3.6\text{ V}$; $T_{amb} = -40\text{ }^{\circ}\text{C to }+85\text{ }^{\circ}\text{C}$; unless otherwise specified.

| Symbol | Parameter | Conditions | Min | Typ | Max | Unit |
|-------------------------------|--|---|-----|-----|-------|------|
| Driver characteristics | | | | | | |
| t _{FR} | rise time | C _L = 50 pF; 10 % to 90 % of V _{OH} - V _{OL} | 4 | - | 20 | ns |
| t _{FF} | fall time | C _L = 50 pF; 90 % to 10 % of V _{OH} - V _{OL} | 4 | - | 20 | ns |
| t _{FRFM} | differential rise and fall time matching | | 90 | - | 111.1 | % |

Data timing: see Figure 10

| | | | | | | |
|--------------------|---|-------------------|------|---|------|----|
| t _{FDEOP} | source jitter for differential transition to SEO transition | full-speed timing | -2 | - | +5 | ns |
| t _{FEOPT} | source SE0 interval of EOP | | 160 | - | 175 | ns |
| t _{FEOPR} | receiver SE0 interval of EOP | | 82 | - | - | ns |
| t _{LDEOP} | source jitter for differential transition to SEO transition | low-speed timing | -40 | - | +100 | ns |
| t _{LEOPT} | source SE0 interval of EOP | | 1.25 | - | 1.5 | μs |
| t _{LEOPR} | receiver SE0 interval of EOP | | 670 | - | - | ns |
| t _{FST} | width of SE0 interval during the differential transaction | | - | - | 14 | ns |

Table 121: Dynamic characteristics: low-speed source electrical characteristics

$V_{DDA_AUX} = 3.0\text{ V to }3.6\text{ V}$; $T_{amb} = -40\text{ }^{\circ}\text{C to }+85\text{ }^{\circ}\text{C}$; unless otherwise specified.

| Symbol | Parameter | Conditions | Min | Typ | Max | Unit |
|-------------------------------|--|------------|-----|-----|-----|------|
| Driver characteristics | | | | | | |
| t _{LR} | rise time | | 75 | - | 300 | ns |
| t _{LF} | fall time | | 75 | - | 300 | ns |
| t _{LRFM} | differential rise and fall time matching | | 90 | - | 125 | % |

16.1 Timing

Table 122: PCI clock and IO timing

| Symbol | Parameter | Conditions | Min | Typ | Max | Unit |
|--|---|------------|-----|-----|-----|-------|
| PCI clock timing; see Figure 7 | | | | | | |
| $T_{cyc}(PCICLK)$ | PCICLK cycle time | | 30 | - | 32 | ns |
| $t_{HIGH}(PCICLK)$ | PCICLK HIGH time | | 11 | - | - | ns |
| $t_{LOW}(PCICLK)$ | PCICLK LOW time | | 11 | - | - | ns |
| SR_{PCICLK} | PCICLK slew rate | | 1 | - | 4 | V/ns |
| $SR_{RST\#}$ | RST# slew rate | | 50 | - | - | mV/ns |
| PCI input timing; see Figure 8 | | | | | | |
| $t_{su}(PCICLK)_{bs}$ | setup time to PCICLK (bus signal) | | 7 | - | - | ns |
| $t_{su}(PCICLK)_{ptp}$ | setup time to PCICLK (point-to-point) | [1] | 10 | - | - | ns |
| $t_h(PCICLK)$ | input hold time from PCICLK | | 0 | - | - | ns |
| PCI output timing; see Figure 9 | | | | | | |
| $t_{val}(PCICLK)_{bs}$ | PCICLK to signal valid delay (bus signal) | | 2 | - | 11 | ns |
| $t_{val}(PCICLK)_{ptp}$ | PCICLK to signal valid delay (point-to-point) | [1] | 2 | - | 12 | ns |
| $t_{dZ(act)}$ | float to active delay | | 2 | - | - | ns |
| $t_{d(act)Z}$ | active to float delay | | - | - | 28 | ns |
| PCI reset timing | | | | | | |
| t_{rst} | reset active time after CLK stable | | 1 | - | - | ms |

[1] REQ# and GNT# are point-to-point signals. GNT# has a setup of 10 ns; REQ# has a setup of 12 ns. All others are bus signals.

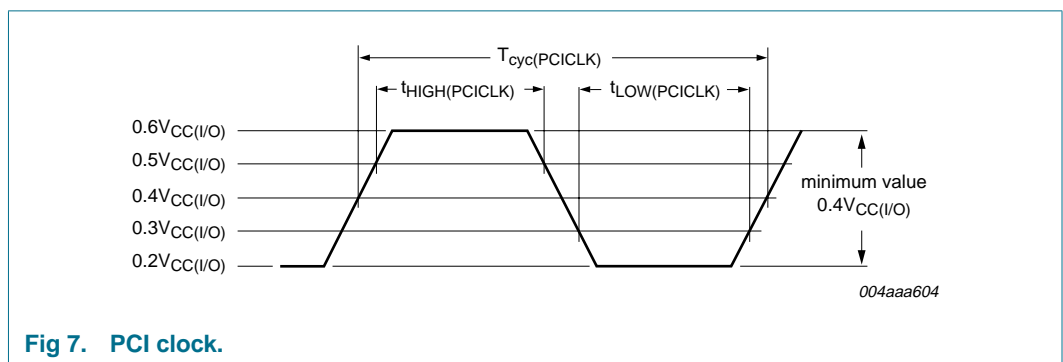

Fig 7. PCI clock.

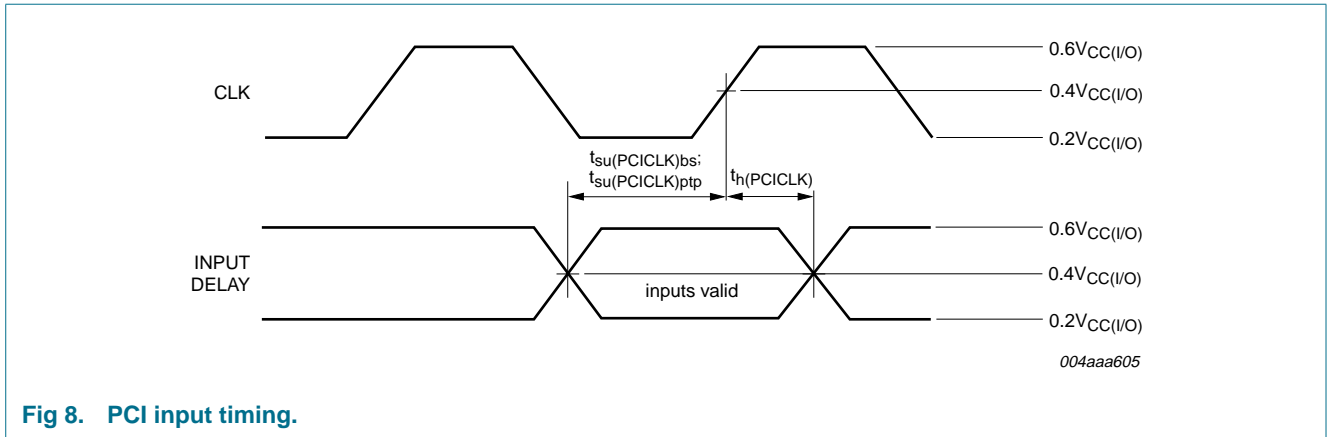

Fig 8. PCI input timing.

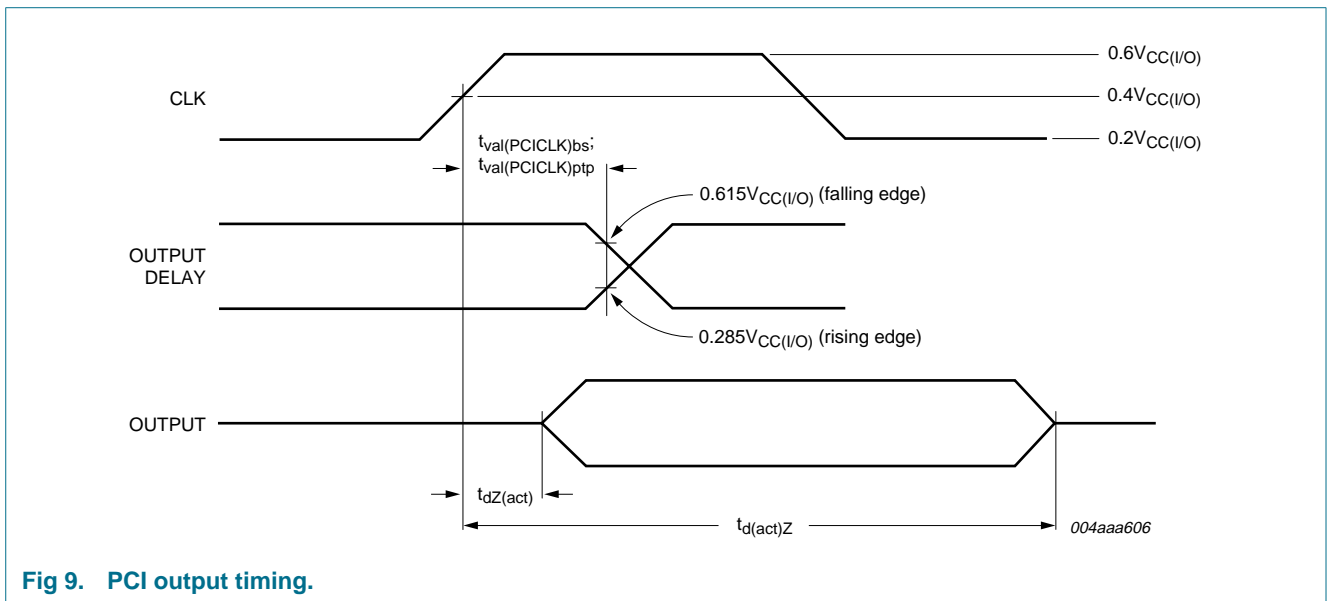

Fig 9. PCI output timing.

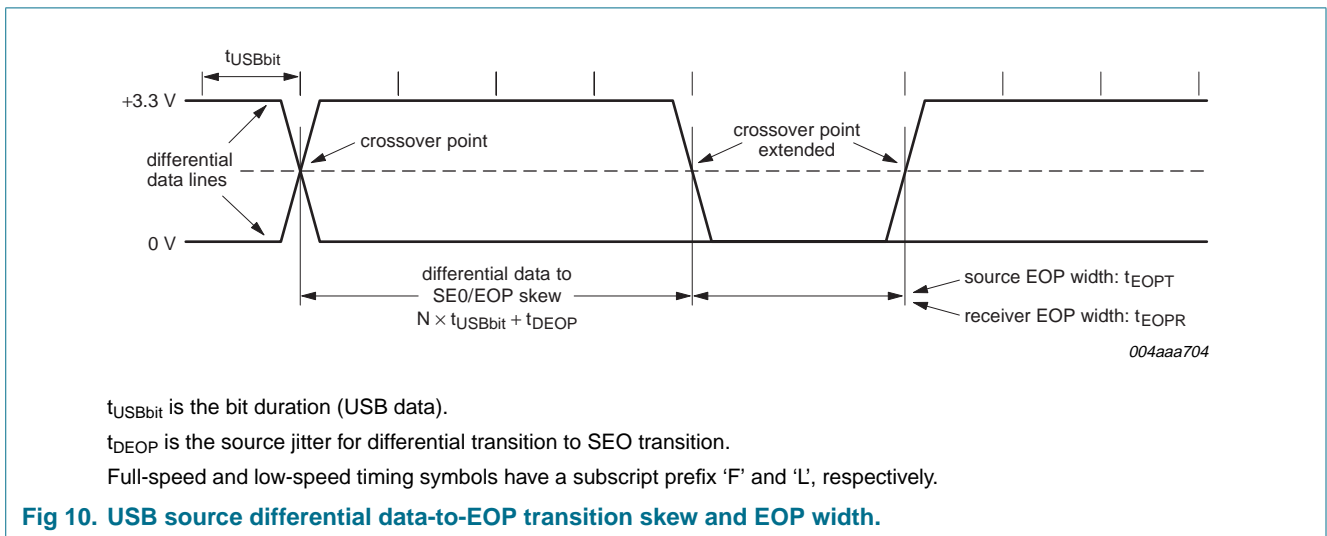

Fig 10. USB source differential data-to-EOP transition skew and EOP width.

17. Package outline

LQFP100: plastic low profile quad flat package; 100 leads; body 14 x 14 x 1.4 mm

SOT407-1

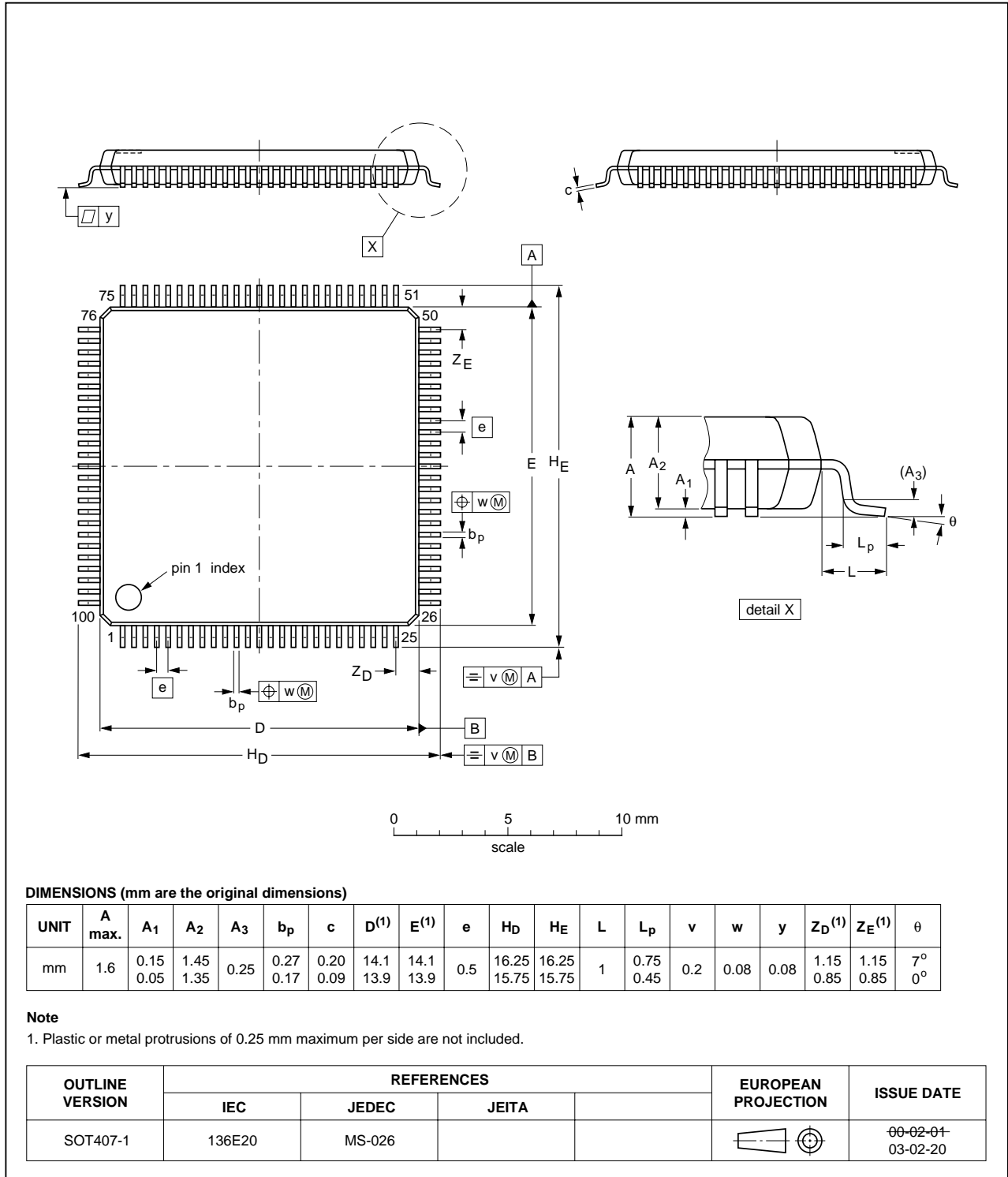

Fig 11. Package outline SOT407-1 (LQFP100).

18. Soldering

18.1 Introduction to soldering surface mount packages

This text gives a very brief insight to a complex technology. A more in-depth account of soldering ICs can be found in our *Data Handbook IC26; Integrated Circuit Packages* (document order number 9398 652 90011).

There is no soldering method that is ideal for all surface mount IC packages. Wave soldering can still be used for certain surface mount ICs, but it is not suitable for fine pitch SMDs. In these situations reflow soldering is recommended.

18.2 Reflow soldering

Reflow soldering requires solder paste (a suspension of fine solder particles, flux and binding agent) to be applied to the printed-circuit board by screen printing, stencilling or pressure-syringe dispensing before package placement. Driven by legislation and environmental forces the worldwide use of lead-free solder pastes is increasing.

Several methods exist for reflowing; for example, convection or convection/infrared heating in a conveyor type oven. Throughput times (preheating, soldering and cooling) vary between 100 seconds and 200 seconds depending on heating method.

Typical reflow peak temperatures range from 215 °C to 270 °C depending on solder paste material. The top-surface temperature of the packages should preferably be kept:

- below 225 °C (SnPb process) or below 245 °C (Pb-free process)
 - for all BGA, HTSSON..T and SSOP..T packages
 - for packages with a thickness ≥ 2.5 mm
 - for packages with a thickness < 2.5 mm and a volume ≥ 350 mm³ so called thick/large packages.
- below 240 °C (SnPb process) or below 260 °C (Pb-free process) for packages with a thickness < 2.5 mm and a volume < 350 mm³ so called small/thin packages.

Moisture sensitivity precautions, as indicated on packing, must be respected at all times.

18.3 Wave soldering

Conventional single wave soldering is not recommended for surface mount devices (SMDs) or printed-circuit boards with a high component density, as solder bridging and non-wetting can present major problems.

To overcome these problems the double-wave soldering method was specifically developed.

If wave soldering is used the following conditions must be observed for optimal results:

- Use a double-wave soldering method comprising a turbulent wave with high upward pressure followed by a smooth laminar wave.
- For packages with leads on two sides and a pitch (e):
 - larger than or equal to 1.27 mm, the footprint longitudinal axis is **preferred** to be parallel to the transport direction of the printed-circuit board;

- smaller than 1.27 mm, the footprint longitudinal axis **must** be parallel to the transport direction of the printed-circuit board.

The footprint must incorporate solder thieves at the downstream end.

- For packages with leads on four sides, the footprint must be placed at a 45° angle to the transport direction of the printed-circuit board. The footprint must incorporate solder thieves downstream and at the side corners.

During placement and before soldering, the package must be fixed with a droplet of adhesive. The adhesive can be applied by screen printing, pin transfer or syringe dispensing. The package can be soldered after the adhesive is cured.

Typical dwell time of the leads in the wave ranges from 3 seconds to 4 seconds at 250 °C or 265 °C, depending on solder material applied, SnPb or Pb-free respectively.

A mildly-activated flux will eliminate the need for removal of corrosive residues in most applications.

18.4 Manual soldering

Fix the component by first soldering two diagonally-opposite end leads. Use a low voltage (24 V or less) soldering iron applied to the flat part of the lead. Contact time must be limited to 10 seconds at up to 300 °C.

When using a dedicated tool, all other leads can be soldered in one operation within 2 seconds to 5 seconds between 270 °C and 320 °C.

18.5 Package related soldering information

Table 123: Suitability of surface mount IC packages for wave and reflow soldering methods

| Package [1] | Soldering method | |
|--|-------------------------|--------------|
| | Wave | Reflow [2] |
| BGA, HTSSON..T [3], LBGA, LFBGA, SQFP, SSOP..T [3], TFBGA, VFBGA, XSON | not suitable | suitable |
| DHVQFN, HBCC, HBGA, HLQFP, HSO, HSOP, HSQFP, HSSON, HTQFP, HTSSOP, HVQFN, HVSON, SMS | not suitable [4] | suitable |
| PLCC [5], SO, SOJ | suitable | suitable |
| LQFP, QFP, TQFP | not recommended [5] [6] | suitable |
| SSOP, TSSOP, VSO, VSSOP | not recommended [7] | suitable |
| CWQCCN..L [8], PMFP [9], WQCCN..L [8] | not suitable | not suitable |

[1] For more detailed information on the BGA packages refer to the *(LF)BGA Application Note (AN01026)*; order a copy from your Philips Semiconductors sales office.

[2] All surface mount (SMD) packages are moisture sensitive. Depending upon the moisture content, the maximum temperature (with respect to time) and body size of the package, there is a risk that internal or external package cracks may occur due to vaporization of the moisture in them (the so called popcorn effect). For details, refer to the Drypack information in the *Data Handbook IC26; Integrated Circuit Packages; Section: Packing Methods*.

[3] These transparent plastic packages are extremely sensitive to reflow soldering conditions and must on no account be processed through more than one soldering cycle or subjected to infrared reflow soldering with peak temperature exceeding 217 °C ± 10 °C measured in the atmosphere of the reflow oven. The package body peak temperature must be kept as low as possible.

- [4] These packages are not suitable for wave soldering. On versions with the heatsink on the bottom side, the solder cannot penetrate between the printed-circuit board and the heatsink. On versions with the heatsink on the top side, the solder might be deposited on the heatsink surface.
- [5] If wave soldering is considered, then the package must be placed at a 45° angle to the solder wave direction. The package footprint must incorporate solder thieves downstream and at the side corners.
- [6] Wave soldering is suitable for LQFP, QFP and TQFP packages with a pitch (e) larger than 0.8 mm; it is definitely not suitable for packages with a pitch (e) equal to or smaller than 0.65 mm.
- [7] Wave soldering is suitable for SSOP, TSSOP, VSO and VSSOP packages with a pitch (e) equal to or larger than 0.65 mm; it is definitely not suitable for packages with a pitch (e) equal to or smaller than 0.5 mm.
- [8] Image sensor packages in principle should not be soldered. They are mounted in sockets or delivered pre-mounted on flex foil. However, the image sensor package can be mounted by the client on a flex foil by using a hot bar soldering process. The appropriate soldering profile can be provided on request.
- [9] Hot bar soldering or manual soldering is suitable for PMFP packages.

19. Abbreviations

Table 124: Abbreviations

| Acronym | Description |
|---------|---|
| CMOS | Complementary Metal-Oxide Semiconductor |
| DID | Device ID |
| EEPROM | Electrically Erasable Programmable Read-Only Memory |
| EHCI | Enhanced Host Controller Interface |
| EMI | Electro-Magnetic Interference |
| ESD | Electro-Static Discharge |
| HC | Host Controller |
| HCCA | Host Controller Communication Area |
| HCD | Host Controller Driver |
| OHCI | Open Host Controller Interface |
| PCI | Peripheral Component Interconnect |
| PCI-SIG | PCI-Special Interest Group |
| PLL | Phase-Locked Loop |
| PMC | Power Management Capabilities |
| PME | Power Management Event |
| PMCSR | Power Management Control/Status |
| POR | Power-On Reset |
| STB | Set-Top Box |
| USB | Universal Serial Bus |
| VID | Vendor ID |

20. References

- [1] Universal Serial Bus Specification Rev. 2.0
- [2] Enhanced Host Controller Interface Specification for Universal Serial Bus Rev. 1.0
- [3] Open Host Controller Interface Specification for USB Rev. 1.0a
- [4] PCI Local Bus Specification Rev. 2.2
- [5] PCI Bus Power Management Interface Specification Rev. 1.1



[6] The I²C-bus Specification, Version 2.1.

21. Revision history

Table 125: Revision history

| Document ID | Release date | Data sheet status | Change notice | Doc. number | Supersedes |
|-------------|--------------|--------------------|---------------|----------------|------------|
| ISP1562_1 | 20050714 | Product data sheet | - | 9397 750 14223 | - |

22. Data sheet status

| Level | Data sheet status ^[1] | Product status ^{[2] [3]} | Definition |
|-------|----------------------------------|-----------------------------------|--|
| I | Objective data | Development | This data sheet contains data from the objective specification for product development. Philips Semiconductors reserves the right to change the specification in any manner without notice. |
| II | Preliminary data | Qualification | This data sheet contains data from the preliminary specification. Supplementary data will be published at a later date. Philips Semiconductors reserves the right to change the specification without notice, in order to improve the design and supply the best possible product. |
| III | Product data | Production | This data sheet contains data from the product specification. Philips Semiconductors reserves the right to make changes at any time in order to improve the design, manufacturing and supply. Relevant changes will be communicated via a Customer Product/Process Change Notification (CPCN). |

[1] Please consult the most recently issued data sheet before initiating or completing a design.

[2] The product status of the device(s) described in this data sheet may have changed since this data sheet was published. The latest information is available on the Internet at URL <http://www.semiconductors.philips.com>.

[3] For data sheets describing multiple type numbers, the highest-level product status determines the data sheet status.

23. Definitions

Short-form specification — The data in a short-form specification is extracted from a full data sheet with the same type number and title. For detailed information see the relevant data sheet or data handbook.

Limiting values definition — Limiting values given are in accordance with the Absolute Maximum Rating System (IEC 60134). Stress above one or more of the limiting values may cause permanent damage to the device. These are stress ratings only and operation of the device at these or at any other conditions above those given in the Characteristics sections of the specification is not implied. Exposure to limiting values for extended periods may affect device reliability.

Application information — Applications that are described herein for any of these products are for illustrative purposes only. Philips Semiconductors make no representation or warranty that such applications will be suitable for the specified use without further testing or modification.

24. Disclaimers

Life support — These products are not designed for use in life support appliances, devices, or systems where malfunction of these products can reasonably be expected to result in personal injury. Philips Semiconductors

26. Contact information

For additional information, please visit: <http://www.semiconductors.philips.com>

For sales office addresses, send an email to: sales.addresses@www.semiconductors.philips.com

customers using or selling these products for use in such applications do so at their own risk and agree to fully indemnify Philips Semiconductors for any damages resulting from such application.

Right to make changes — Philips Semiconductors reserves the right to make changes in the products - including circuits, standard cells, and/or software - described or contained herein in order to improve design and/or performance. When the product is in full production (status 'Production'), relevant changes will be communicated via a Customer Product/Process Change Notification (CPCN). Philips Semiconductors assumes no responsibility or liability for the use of any of these products, conveys no license or title under any patent, copyright, or mask work right to these products, and makes no representations or warranties that these products are free from patent, copyright, or mask work right infringement, unless otherwise specified.

25. Trademarks

Notice — All referenced brands, product names, service names and trademarks are the property of their respective owners.

I²C-bus — wordmark and logo are trademarks of Koninklijke Philips Electronics N.V.

27. Tables

| | | | |
|--|----|--|----|
| Table 1: Ordering information | 2 | (address 61h) bit allocation | 24 |
| Table 2: Pin description | 5 | Table 28: FLADJ - Frame Length Adjustment register (address 61h) bit description | 24 |
| Table 3: PCI configuration space registers of OHCI1, OHCI2 and EHCI | 13 | Table 29: PORTWAKECAP - Port Wake Capability register (address 62h) bit description | 25 |
| Table 4: VID - Vendor ID register (address 00h) bit description | 15 | Table 30: Power Management registers | 25 |
| Table 5: DID - Device ID register (address 02h) bit description | 15 | Table 31: Cap_ID - Capability Identifier register bit description | 25 |
| Table 6: Command register (address 04h) bit allocation | 15 | Table 32: Next_Item_Ptr - Next Item Pointer register bit description | 26 |
| Table 7: Command register (address 04h) bit description | 16 | Table 33: PMC - Power Management Capabilities register bit allocation | 26 |
| Table 8: Status register (address 06h) bit allocation | 17 | Table 34: PMC - Power Management Capabilities register bit description | 26 |
| Table 9: Status register (address 06h) bit description | 17 | Table 35: PMCSR - Power Management Control/Status register bit allocation | 28 |
| Table 10: REVID - Revision ID register (address 08h) bit description | 18 | Table 36: PMCSR - Power Management Control/Status register bit description | 28 |
| Table 11: Class Code register (address 09h) bit allocation | 19 | Table 37: PMCSR_BSE - PMCSR PCI-to-PCI Bridge Support Extensions register bit allocation | 29 |
| Table 12: Class Code register (address 09h) bit description | 19 | Table 38: PMCSR_BSE - PMCSR PCI-to-PCI Bridge Support Extensions register bit description | 30 |
| Table 13: CLS - CacheLine Size register (address 0Ch) bit description | 20 | Table 39: PCI bus power and clock control | 30 |
| Table 14: LT - Latency Timer register (address 0Dh) bit description | 20 | Table 40: Data register bit description | 30 |
| Table 15: Header Type register (address 0Eh) bit allocation | 20 | Table 41: USB Host Controller registers | 33 |
| Table 16: Header Type register (address 0Eh) bit description | 20 | Table 42: HcRevision - Host Controller Revision register bit allocation | 34 |
| Table 17: BAR 0 - Base Address register 0 (address 10h) bit description | 21 | Table 43: HcRevision - Host Controller Revision register bit description | 35 |
| Table 18: SVID - Subsystem Vendor ID register (address 2Ch) bit description | 21 | Table 44: HcControl - Host Controller Control register bit allocation | 35 |
| Table 19: SID - Subsystem ID register (address 2Eh) bit description | 21 | Table 45: HcControl - Host Controller Control register bit description | 36 |
| Table 20: CP - Capabilities Pointer register (address 34h) bit description | 21 | Table 46: HcCommandStatus - Host Controller Command Status register bit allocation | 38 |
| Table 21: IL - Interrupt Line register (address 3Ch) bit description | 22 | Table 47: HcCommandStatus - Host Controller Command Status register bit description | 38 |
| Table 22: IP - Interrupt Pin register (address 3Dh) bit description | 22 | Table 48: HcInterruptStatus - Host Controller Interrupt Status register bit allocation | 39 |
| Table 23: Min_Gnt - Minimum Grant register (address 3Eh) bit description | 22 | Table 49: HcInterruptStatus - Host Controller Interrupt Status register bit description | 40 |
| Table 24: Max_Lat - Maximum Latency register (address 3Fh) bit description | 23 | Table 50: HcInterruptEnable - Host Controller Interrupt Enable register bit allocation | 41 |
| Table 25: EHCI-specific PCI registers | 23 | Table 51: HcInterruptEnable - Host Controller Interrupt Enable register bit description | 41 |
| Table 26: SBRN - Serial Bus Release Number register (address 60h) bit description | 24 | Table 52: HcInterruptDisable - Host Controller Interrupt Disable register bit allocation | 42 |
| Table 27: FLADJ - Frame Length Adjustment register (address 61h) bit allocation | 24 | Table 53: HcInterruptDisable - Host Controller | |

continued >>

| | | | | | |
|-----------|---|----|-----------|--|----|
| Table 54: | HcHCCA - Host Controller Communication Area register bit allocation | 44 | Table 75: | HcPeriodicStart - Host Controller Periodic Start register bit description | 53 |
| Table 55: | HcHCCA - Host Controller Communication Area register bit description | 44 | Table 76: | HcLSThreshold - Host Controller LS Threshold register bit allocation | 53 |
| Table 56: | HcPeriodCurrentED - Host Controller Period Current Endpoint Descriptor register bit allocation | 44 | Table 77: | HcLSThreshold - Host Controller LS Threshold register bit description | 54 |
| Table 57: | HcPeriodCurrentED - Host Controller Period Current Endpoint Descriptor register bit description | 45 | Table 78: | HcRhDescriptorA - Host Controller Root Hub Descriptor A register bit allocation | 54 |
| Table 58: | HcControlHeadED - Host Controller Control Head Endpoint Descriptor register bit allocation | 45 | Table 79: | HcRhDescriptorA - Host Controller Root Hub Descriptor A register bit description | 55 |
| Table 59: | HcControlHeadED - Host Controller Control Head Endpoint Descriptor register bit description | 46 | Table 80: | HcRhDescriptorB - Host Controller Root Hub Descriptor B register bit allocation | 56 |
| Table 60: | HcControlCurrentED - Host Controller Control Current Endpoint Descriptor register bit allocation | 46 | Table 81: | HcRhDescriptorB - Host Controller Root Hub Descriptor B register bit description | 56 |
| Table 61: | HcControlCurrentED - Host Controller Control Current Endpoint Descriptor register bit description | 46 | Table 82: | HcRhStatus - Host Controller Root Hub Status register bit allocation | 57 |
| Table 62: | HcBulkHeadED - Host Controller Bulk Head Endpoint Descriptor register bit allocation | 47 | Table 83: | HcRhStatus - Host Controller Root Hub Status register bit description | 57 |
| Table 63: | HcBulkHeadED - Host Controller Bulk Head Endpoint Descriptor register bit description | 47 | Table 84: | HcRhPortStatus[4:1] - Host Controller Root Hub Port Status[4:1] register bit allocation | 58 |
| Table 64: | HcBulkCurrentED - Host Controller Bulk Current Endpoint Descriptor register bit allocation | 47 | Table 85: | HcRhPortStatus[4:1] - Host Controller Root Hub Port Status[4:1] register bit description | 59 |
| Table 65: | HcBulkCurrentED - Host Controller Bulk Current Endpoint Descriptor register bit description | 48 | Table 86: | CAPLENGTH/HCIVERSION - Capability Registers Length/Host Controller Interface Version Number register bit allocation | 62 |
| Table 66: | HcDoneHead - Host Controller Done Head register bit allocation | 48 | Table 87: | CAPLENGTH/HCIVERSION - Capability Registers Length/Host Controller Interface Version Number register bit description | 62 |
| Table 67: | HcDoneHead - Host Controller Done Head register bit description | 49 | Table 88: | HCSPARAMS - Host Controller Structural Parameters register bit allocation | 62 |
| Table 68: | HcFmInterval - Host Controller Frame Interval register bit allocation | 49 | Table 89: | HCSPARAMS - Host Controller Structural Parameters register bit description | 63 |
| Table 69: | HcFmInterval - Host Controller Frame Interval register bit description | 50 | Table 90: | HCCPARAMS - Host Controller Capability Parameters register bit allocation | 64 |
| Table 70: | HcFmRemaining - Host Controller Frame Remaining register bit allocation | 51 | Table 91: | HCCPARAMS - Host Controller Capability Parameters register bit description | 64 |
| Table 71: | HcFmRemaining - Host Controller Frame Remaining register bit description | 51 | Table 92: | USBCMD - USB Command register bit allocation | 65 |
| Table 72: | HcFmNumber - Host Controller Frame Number register bit allocation | 51 | Table 93: | USBCMD - USB Command register bit description | 66 |
| Table 73: | HcFmNumber - Host Controller Frame Number register bit description | 52 | Table 94: | USBSTS - USB Status register bit allocation | 68 |
| Table 74: | HcPeriodicStart - Host Controller Periodic Start register bit allocation | 52 | Table 95: | USBSTS - USB Status register bit description | 68 |
| | | | Table 96: | USBINTR - USB Interrupt Enable register bit allocation | 70 |
| | | | Table 97: | USBINTR - USB Interrupt Enable register bit description | 70 |
| | | | Table 98: | FRINDEX - Frame Index register bit allocation | 71 |
| | | | Table 99: | FRINDEX - Frame Index register bit | |

continued >>

description72

Table 100:PERIODICLISTBASE - Periodic Frame List
Base Address register bit allocation72

Table 101:PERIODICLISTBASE - Periodic Frame List
Base Address register bit description73

Table 102:ASYNCLISTADDR - Current Asynchronous
List Address register bit allocation73

Table 103:ASYNCLISTADDR - Current Asynchronous
List Address register bit description74

Table 104:CONFIGFLAG - Configure Flag register
bit allocation74

Table 105:CONFIGFLAG - Configure Flag register
bit description74

Table 106:PORTSC 1, 2 - Port Status and Control 1, 2
register bit allocation75

Table 107:PORTSC 1, 2 - Port Status and Control 1, 2
register bit description75

Table 108:Power consumption79

Table 109:Power consumption: S1 and S379

Table 110:Limiting values80

Table 111:Recommended operating conditions80

Table 112:Static characteristics: I²C-bus interface
(SDA and SCL)81

Table 113:Static characteristics: digital pins81

Table 114:Static characteristics: PCI interface block ...81

Table 115:Static characteristics: USB interface block
(pins DM1 to DM2 and DP1 to DP2)81

Table 116:Dynamic characteristics: system clock
timing83

Table 117:Dynamic characteristics: I²C-bus interface
(SDA and SCL)83

Table 118:Dynamic characteristics: PCI interface
block83

Table 119:Dynamic characteristics: high-speed source
electrical characteristics83

Table 120:Dynamic characteristics: full-speed source
electrical characteristics84

Table 121:Dynamic characteristics: low-speed source
electrical characteristics84

Table 122:PCI clock and IO timing85

Table 123:Suitability of surface mount IC packages for
wave and reflow soldering methods89

Table 124:Abbreviations90

Table 125:Revision history91

continued >>



28. Figures

| | | |
|---------|---|----|
| Fig 1. | Block diagram. | 3 |
| Fig 2. | Pin configuration. | 4 |
| Fig 3. | Power-on reset. | 11 |
| Fig 4. | Power supply connection. | 12 |
| Fig 5. | EEPROM connection diagram. | 31 |
| Fig 6. | Information loading from EEPROM. | 32 |
| Fig 7. | PCI clock. | 85 |
| Fig 8. | PCI input timing. | 86 |
| Fig 9. | PCI output timing. | 86 |
| Fig 10. | USB source differential data-to-EOP transition skew and EOP width. | 86 |
| Fig 11. | Package outline SOT407-1 (LQFP100). | 87 |

continued >>

29. Contents

| | | | | | |
|----------|--|-----------|-----------|--|-----------|
| 1 | General description | 1 | 8.2.3 | Power management registers. | 25 |
| 2 | Features | 1 | 8.2.3.1 | Cap_ID register | 25 |
| 3 | Applications | 2 | 8.2.3.2 | Next_Item_Ptr register | 25 |
| 4 | Ordering information | 2 | 8.2.3.3 | PMC register | 26 |
| 5 | Block diagram | 3 | 8.2.3.4 | PMCSR register | 27 |
| 6 | Pinning information | 4 | 8.2.3.5 | PMCSR_BSE register | 29 |
| 6.1 | Pinning | 4 | 8.2.3.6 | Data register. | 30 |
| 6.2 | Pin description | 5 | 9 | I²C-bus interface | 31 |
| 7 | Functional description | 10 | 9.1 | Protocol | 31 |
| 7.1 | OHCI Host Controller | 10 | 9.2 | Hardware connections | 31 |
| 7.2 | EHCI Host Controller | 10 | 9.3 | Information loading from EEPROM | 32 |
| 7.3 | Dynamic port-routing logic | 10 | 10 | Power management. | 32 |
| 7.4 | Hi-Speed USB analog transceivers | 10 | 10.1 | PCI bus power states | 32 |
| 7.5 | Power management | 10 | 10.2 | USB bus states | 33 |
| 7.6 | Phase-Locked Loop (PLL) | 10 | 11 | USB Host Controller registers | 33 |
| 7.7 | Power-On Reset (POR) | 11 | 11.1 | OHCI USB Host Controller operational | |
| 7.8 | Power supply | 11 | | registers | 34 |
| 8 | PCI | 12 | 11.1.1 | HcRevision register | 34 |
| 8.1 | PCI interface | 12 | 11.1.2 | HcControl register | 35 |
| 8.1.1 | PCI configuration space | 13 | 11.1.3 | HcCommandStatus register | 37 |
| 8.1.2 | PCI initiator and target | 13 | 11.1.4 | HcInterruptStatus register | 39 |
| 8.2 | PCI configuration registers | 13 | 11.1.5 | HcInterruptEnable register | 41 |
| 8.2.1 | PCI configuration header registers | 14 | 11.1.6 | HcInterruptDisable register | 42 |
| 8.2.1.1 | Vendor ID register. | 14 | 11.1.7 | HcHCCA register | 44 |
| 8.2.1.2 | Device ID register | 15 | 11.1.8 | HcPeriodCurrentED register. | 44 |
| 8.2.1.3 | Command register | 15 | 11.1.9 | HcControlHeadED register. | 45 |
| 8.2.1.4 | Status register. | 17 | 11.1.10 | HcControlCurrentED register. | 46 |
| 8.2.1.5 | Revision ID register | 18 | 11.1.11 | HcBulkHeadED register | 47 |
| 8.2.1.6 | Class Code register | 18 | 11.1.12 | HcBulkCurrentED register | 47 |
| 8.2.1.7 | CacheLine Size register | 19 | 11.1.13 | HcDoneHead register | 48 |
| 8.2.1.8 | Latency Timer register | 20 | 11.1.14 | HcFmInterval register. | 49 |
| 8.2.1.9 | Header Type register | 20 | 11.1.15 | HcFmRemaining register | 50 |
| 8.2.1.10 | Base Address register 0 | 20 | 11.1.16 | HcFmNumber register | 51 |
| 8.2.1.11 | Subsystem Vendor ID register | 21 | 11.1.17 | HcPeriodicStart register | 52 |
| 8.2.1.12 | Subsystem ID register | 21 | 11.1.18 | HcLSThreshold register | 53 |
| 8.2.1.13 | Capabilities Pointer register | 21 | 11.1.19 | HcRhDescriptorA register | 54 |
| 8.2.1.14 | Interrupt Line register | 22 | 11.1.20 | HcRhDescriptorB register | 55 |
| 8.2.1.15 | Interrupt Pin register | 22 | 11.1.21 | HcRhStatus register | 56 |
| 8.2.1.16 | Min_Gnt and Max_Lat registers | 22 | 11.1.22 | HcRhPortStatus[4:1] register | 58 |
| 8.2.1.17 | TRDY Timeout register | 23 | 11.2 | EHCI controller capability registers | 61 |
| 8.2.1.18 | Retry Timeout register | 23 | 11.2.1 | CAPLENGTH/HCIVERSION register. | 61 |
| 8.2.2 | Enhanced Host Controller-specific PCI | | 11.2.2 | HCSPARAMS register | 62 |
| | registers | 23 | 11.2.3 | HCCPARAMS register | 64 |
| 8.2.2.1 | SBRN register. | 23 | 11.2.4 | HCSP-PORTROUTE register. | 65 |
| 8.2.2.2 | FLADJ register | 24 | 11.3 | Operational registers of Enhanced USB | |
| 8.2.2.3 | PORTWAKECAP register | 24 | 11.3.1 | Host Controller | 65 |
| | | | | USBCMD register. | 65 |

continued >>

| | | |
|-----------|--|-----------|
| 11.3.2 | USBSTS register | 67 |
| 11.3.3 | USBINTR register | 69 |
| 11.3.4 | FRINDEX register | 71 |
| 11.3.5 | PERIODICLISTBASE register | 72 |
| 11.3.6 | ASYNCLISTADDR register | 73 |
| 11.3.7 | CONFIGFLAG register | 74 |
| 11.3.8 | PORTSC registers 1, 2 | 74 |
| 12 | Power consumption | 79 |
| 13 | Limiting values | 80 |
| 14 | Recommended operating conditions | 80 |
| 15 | Static characteristics | 81 |
| 16 | Dynamic characteristics | 83 |
| 16.1 | Timing | 85 |
| 17 | Package outline | 87 |
| 18 | Soldering | 88 |
| 18.1 | Introduction to soldering surface mount packages | 88 |
| 18.2 | Reflow soldering | 88 |
| 18.3 | Wave soldering | 88 |
| 18.4 | Manual soldering | 89 |
| 18.5 | Package related soldering information | 89 |
| 19 | Abbreviations | 90 |
| 20 | References | 90 |
| 21 | Revision history | 91 |
| 22 | Data sheet status | 92 |
| 23 | Definitions | 92 |
| 24 | Disclaimers | 92 |
| 25 | Trademarks | 92 |
| 26 | Contact information | 92 |



© Koninklijke Philips Electronics N.V. 2005

All rights are reserved. Reproduction in whole or in part is prohibited without the prior written consent of the copyright owner. The information presented in this document does not form part of any quotation or contract, is believed to be accurate and reliable and may be changed without notice. No liability will be accepted by the publisher for any consequence of its use. Publication thereof does not convey nor imply any license under patent- or other industrial or intellectual property rights.

Date of release: 14 July 2005
Document number: 9397 750 14223

Published in The Netherlands